

Qconnect Set Up Instruction

Manual

QMotion QConnect

© HomeRun Holdings Corporation
3400 Copter Road
Pensacola, FL 32514
Phone 877.849.6070 • Fax 850.208.3404
QMotion@homerunholdings.com

Table of Contents

Contents

FCC COMPLIANCE.....	2
• Consult the dealer or an experience radio/TV technician for help. 2	
INDUSTRY CANADA COMPLIANCE	2
PRECAUTIONS STATEMENT	4
Checking supplied accessories.....	5
Identifying the parts.....	6
CONNECTOR PIN OUT	7
ASSEMBLY	9
MOUNTING INSTRUCTIONS.....	9
LED ACTIVITY.....	9
ROTARY SELECTOR.....	10
THEORY OF OPERATION.....	11
INTERFACE CABLE OPTIONS.....	12
SELECTING THE INTERFACE (RS232, RS485, DRY CONTACT).....	13
RS232 OPERATION.....	14
RS485 OPERATION.....	16
DRY CONTACT OPERATION	17
BATTERY POWERED OPERATION	20

INTRODUCTION

Homerun Holdings QMotion QConnect is a multifunctional device. It uses QMotion RF technology and both dry contact and serial interfaces to act as a shade controller in your installation. This manual will guide you through the setup and understanding of your QConnect functions. Once installed, your QMotion QConnect can be used to control various types of QMotion shades.

FCC COMPLIANCE

Warning: Changes or modifications to this device not expressly approved by HomeRun Holdings Corp. could void the user's authority to operate the equipment.

Note: This equipment has been tested and found to comply with the limits for a Class B digital device, pursuant to Part 15 of the FCC Rules. These limits are designed to provide reasonable protection against harmful interference in a residential installation. This equipment generates, uses, and can radiate radio frequency energy and, if not installed and used in accordance with the instructions, may cause harmful interference to radio communications. However, there is no guarantee that interference will not occur in a particular installation. If this equipment does cause harmful interference to radio or television reception, which can be determined by turning the equipment off and on, the user is encouraged to try to correct the interference by one or more of the following measures:

- Reorient or relocate the receiving antenna.
- Increase the separation between the equipment and the receiver.
- Connect the equipment into an outlet on a circuit different from that to which the receiver is connected.
- Consult the dealer or an experience radio/TV technician for help.

INDUSTRY CANADA COMPLIANCE

Under Industry Canada regulations, this radio transmitter may only operate using an antenna of a type and maximum (or lesser) gain approved for the transmitter by Industry Canada. To reduce potential radio interference to other users, the antenna type and its gain should be so chosen that the equivalent isotropically radiated power (e.i.r.p.) is not more than that necessary for successful communication.

Conformément à la réglementation d'Industrie Canada, le présent émetteur radio peut fonctionner avec une antenne d'un type et d'un gain maximal (ou inférieur) approuvé pour l'émetteur par Industrie Canada. Dans le but de réduire les risques de brouillage radioélectrique à l'intention des autres utilisateurs, il faut choisir le type d'antenne et son gain de sorte que la puissance isotrope rayonnée équivalente (p.i.r.e.) ne dépasse pas l'intensité nécessaire à l'établissement d'une communication satisfaisante.

This radio transmitter, Model: Q0244, has been approved by Industry Canada to operate with types listed below with the maximum permissible gain and required antenna impedance for each antenna type indicated. Antenna types not included in this list, having a gain greater than the maximum indicated for that type, are strictly prohibited for use with this device.

Le présent émetteur radio (identifier le dispositif par son numéro de certification ou son numéro de modèle s'il fait partie du matériel de catégorie I) a été approuvé par Industrie Canada pour fonctionner avec les types d'antenne énumérés ci-dessous et ayant un gain admissible maximal et l'impédance requise pour chaque type d'antenne. Les types d'antenne non inclus dans cette liste, ou dont le gain est supérieur au gain maximal indiqué, sont strictement interdits pour l'exploitation de l'émetteur.

Approved antenna: TA040130 433MHz RP-SMA swivel antenna, 50Ω, 2.5dBi

Note to regulatory agencies: The above number is the antenna manufacturer's part number. We, HomeRun Holdings Corporation, will be replacing this part number with our internal HRH part number in the published manuals that shall reference the antenna manufacturer's part number. We have not created our part number for this yet.

This device complies with Industry Canada license-exempt RSS standard(s). Operation is subject to the following two conditions: (1) this device may not cause interference, and (2) this device must accept any interference, including interference that may cause undesired operation of the device.

Le présent appareil est conforme aux CNR d'Industrie Canada applicables aux appareils radio exempts de licence. L'exploitation est autorisée aux deux conditions suivantes : (1) l'appareil ne doit pas produire de brouillage, et (2) l'utilisateur de l'appareil doit accepter tout brouillage radioélectrique subi, même si le brouillage est susceptible d'en compromettre le fonctionnement.

PRECAUTIONS STATEMENT

- The QMotion Qconnect is designed for indoor use only, it may be installed in an outdoor location ONLY when fitted inside a weather proof plastic enclosure and following the recommendations for installation that comes with the weather proof enclosure.
If the QConnect gets wet or is installed in a location where humidity may condensate on to the unit, it may cause the unit to malfunction, this type of malfunction cannot be repaired and is not covered by the warranty.
- The QConnect is designed to operate between 120°F or 48°C and 40°F or 5°C, exposure to temperatures outside this range, such as in an attic or in direct sunlight may cause damage to the unit and/or damage to the property.
- The Qconnect is an RF device, as such please keep in mind that metal will effect the range of the transmissions, try to as little metal as possible in the line of transmission to aid the transmission range.
- Try to locate the Qconnect in the most central location with regard to the BLINDS not the control system.
- You may need more than 1 QConnect per property due to the size of the property or the construction materials.
- In the event of long cable runs, please keep in mind that induction may be an issue for the control cable if it is run adjacent to power line.
- Before using the Qconnect please insure that the blinds to be controlled by the Qconnect are functioning correctly and that all limits have been set via either a single channel remote or a multi channel remote.

Checking supplied accessories

Check that the following accessories were supplied with your QMotion QConnect.

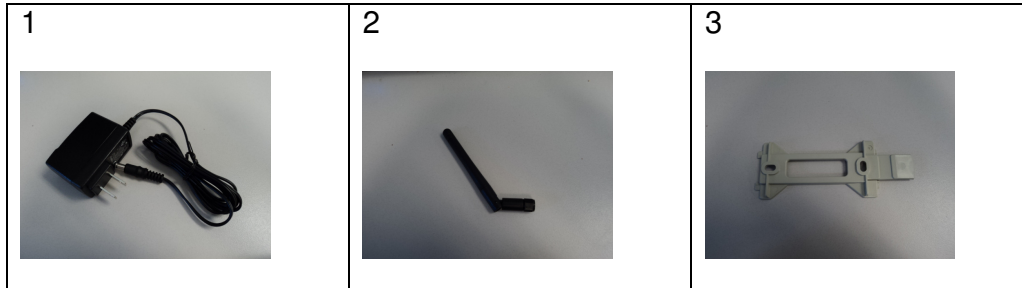

- 1 WRG05F-050A AC power adapter.
- 2 TA040130 433MHz RP-SMA swivel antenna.

Note: If a new antenna is needed it must be ordered from HomeRun Holdings Corporation to ensure continued compliance with FCC and Industry Canada.

- 3 B1360048 Wall mount kit.

Identifying the parts

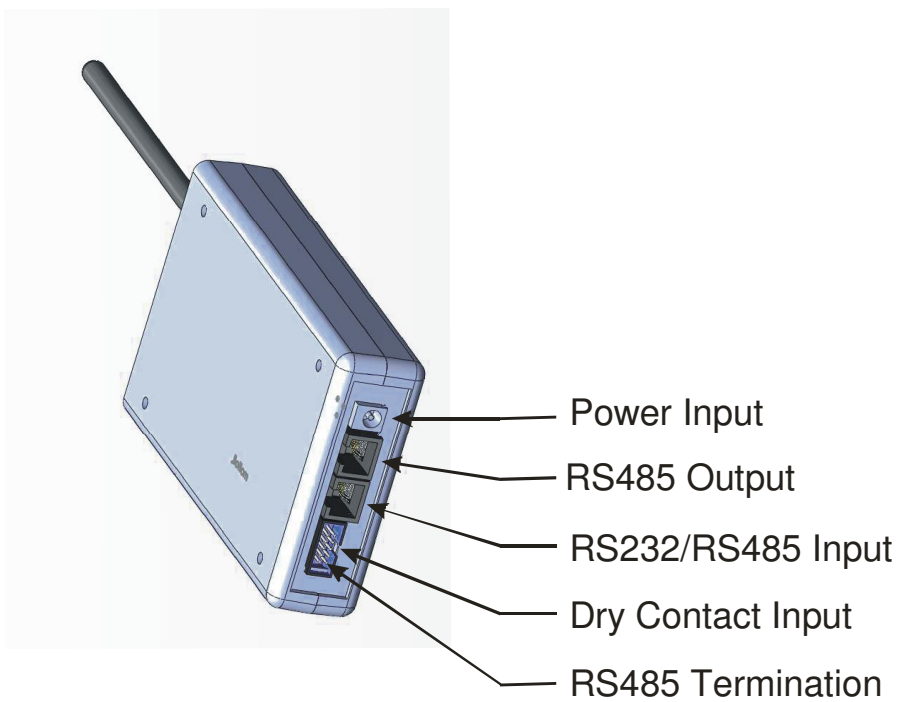
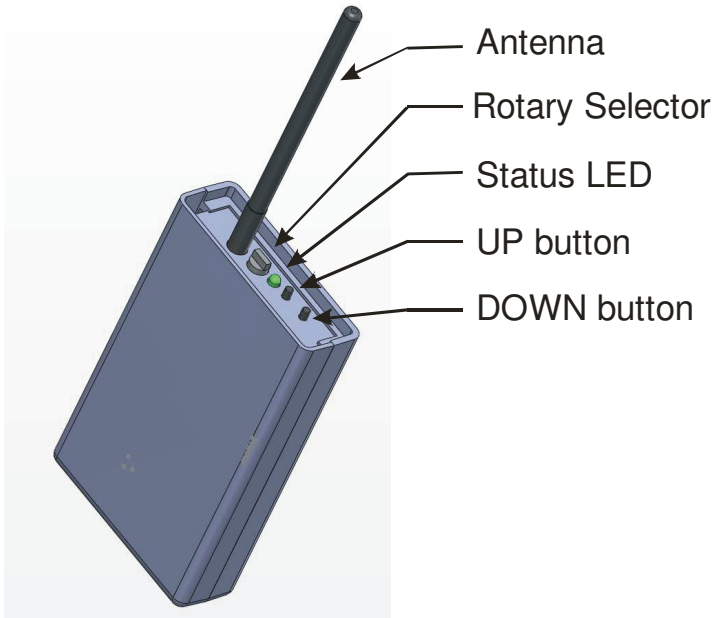

RS232 / RS485 CONNECTOR PIN OUT

The QMotion QConnect has two RJ45 connectors and one 10 pin keyed male header. The pin out description is as follows:

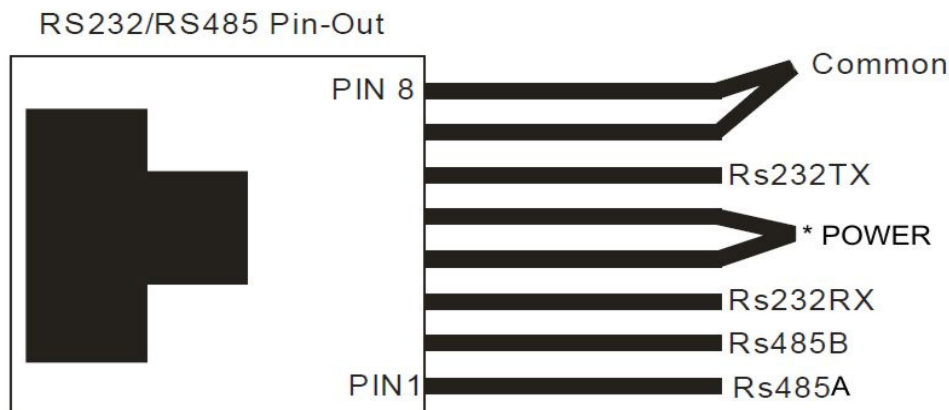

The RJ-45 connector is shown tab side down (This is how the device should be wired, so the controlling device's Rs232 TX should connect to the QConnect's pin 6 and the RS232 RX should go to pin 3)

You will need to make the control wire with an RJ45 connector on the Qconnect end, this can be either 568A or 568B. You will need to make a note of the wire colors you are using following the Pin-Out info above.

For the 3rd party control system termination end you will have to follow the manufacturers information re the type of connector and the Pin-Out of that connector.

The control link between the Qconnect will need to be run from the installation location of the Qconnect back to the relevant control port on the 3rd party controller and then tested.

*NOTE: optional. Power to the QMotion QConnect can be supplied on pins 4/5 and 7/8. By providing 5-9VDC positive on pins 4 and 5 and power ground on pins 7 and 8 the QMotion QConnect can be powered via the CAT5 cable. The power supplied on the RS485 input is daisy-chained on the RS485 output jack. In this way multiple QMotion QConnect devices can be powered without the need for the connection of the external power supply.

The power supply used to provide power over cable should be sized based on the number of QMotion QConnect devices connected on the same run. Supply sizing for multiple bridges should allow for 1W at 5V for each QMotion QConnect, and consideration for voltage drop on the cable if there are long runs between units.

NOTE: The QMotion QConnect does not operate on “standard” power over Ethernet schemes. Do not attempt to connect the QMotion QConnect to any Ethernet device. Do not attempt to connect the QMotion QConnect to any POE (power over Ethernet) device. Doing so, may damage the QMotion QConnect and/or the external Ethernet or POE device. To power the QMotion QConnect over the RJ45 (RS485) interface, you must follow the optional power instructions listed above.

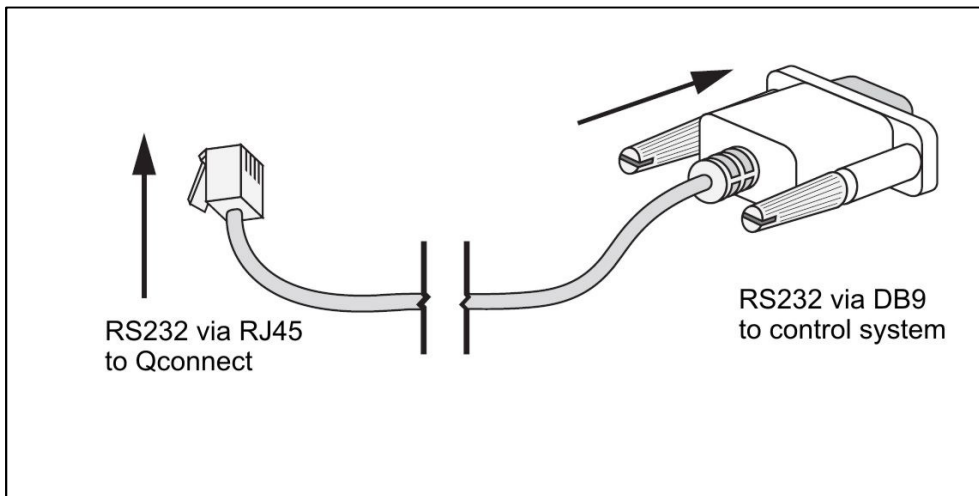

ASSEMBLY

To use your QMotion QConnect it is necessary to attach the supplied swivel RP-SMA antenna. To attach the antenna, carefully align the antenna connector with the antenna base and screw the antenna on in a clock wise direction. Do not over tighten the antenna.

MOUNTING INSTRUCTIONS

The QMotion QConnect can be mounted to a wall or such by using the supplied wall mount kit. The wall mount kit is designed to allow easy removal of the Bridge. Mount the wall mount kit adapter using suitable anchors for the wall material. For best results, do not mount the QMotion QConnect on a metal or metal containing wall. For best results, mount the bridge with the antenna pointing up in the highest location possible near the group or bank of shades to be controlled.

LED ACTIVITY

The QMotion QConnect LED indicates the following:

While externally powered:

- A solid red light indicates the bridge is in RS-232 mode.
- A solid green light indicates the bridge is in RS-485 mode.
- A solid amber light indicates the bridge is in Dry-Contact mode.

While battery powered:

- Pushing the down button will cause the light to turn red while it is transmitting.
- Pushing the up button will cause the light to turn green while it is transmitting.
- Holding both buttons together will cause the light to turn amber indicating the special function command is being transmitted.

ROTARY SELECTOR

The QMotion QConnect Rotary Selector is used for two functions.

When external power is absent from the QMotion QConnect, the Rotary selector is used to pick one of 15 unique groups (or addresses) to learn to each QMotion powered shade. By selecting the group (address) with the Rotary selector and then pressing the UP and DOWN buttons, it is possible to learn and control a QMotion powered shade manually with the QMotion QConnect. For learning the QConnect to a shade please see Battery Powered Operation.

When external power is present on the QMotion QConnect, the Rotary selector is used to uniquely identify the Bridge on a daisy chain of Bridges connected with RS485 communication protocol. The rotary switch is set to Zero when using RS232 mode on the first QConnect. However it is possible to daisy chain multiple QConnects when using an RS232 connection. The first QConnect will have its rotary switch set to Zero and therefore will be in RS232 mode with an ID of **One**. To daisy chain more QConnects simply set the rest of the QConnects to RS485 mode and set their ID's using the rotary switch and daisy chain them to the QConnect that is in RS232 mode.

THEORY OF OPERATION

The QMotion QConnect is a part of HomeRun Holdings QMotion RF controls. The QMotion QConnect is ideal for any residential or commercial setting where a serial interface or dry contact interface is required to integrate with a third party automation system. This is done through a RS485 or RS232 connection or a dry contact connection with an external control system such as a PC or automation system. Integration of the QMotion QConnect requires custom programming on the part of the third party control system. The third party control system must implement the serial protocol commands as defined later in this manual in order to send commands to the QMotion QConnect. The QMotion QConnect receives the serial or dry contact commands and translates them into QMotion RF commands.

The QMotion QConnect has two modes of operation. A battery mode, and an always powered mode (via supplied adapter, or optional serial power).

The battery mode of the QMotion QConnect is used to allow portability of the device without needing cables. This mode is useful for setting up new shades and groupings of shades. The QMotion QConnect has two push buttons, UP and DOWN. These buttons are used for learning new shades and for testing shades locally. These buttons are not functional when the QMotion QConnect is externally powered. The internal battery of the QMotion QConnect should last several years if used as intended for the training and testing of new shades. The serial interfaces and the dry contact interface are not functional in battery mode. For learning the QConnect to a shade please see Battery Powered Operation.

The always powered mode (via supplied adapter, or optional serial power) is the everyday way in which the QMotion QConnect will be used. In this mode the serial interfaces and the dry contact interface are available. To use this mode it is necessary to first setup your QMotion shades to be learned to the QMotion QConnect (refer to battery mode above). The interface for normal operation must be selected before attempting to control the QMotion QConnect with either of the serial interfaces or the dry contact interface. The interface mode selection is described later in this document.

INTERFACE CABLE OPTIONS

The QMotion QConnect utilizes standard RJ-45 connector for both the RS232 and RS485 interfaces. The pin-out of the signals for the RS232 connection and the RS485 connection is described in the RJ-45 pin out diagram earlier in this document. The QMotion QConnect is **not an Ethernet device**, yet for daisy chaining multiple QConnect devices, standard CAT5 patch cables may be used. For connecting the QConnect to an external control system, a custom cable will be needed in order to bring the control signals from the control system to the QConnect. Please refer the RJ-45 pin out diagram earlier in this document. There are two RJ-45 jacks on the QConnect. One is labeled “RS232/RS485 IN” and one labeled “RS485 OUT”. Any standard RJ45 connector can be used.

The RS232/RS485 IN jack is used for making connection to a third party control system. Either the RS232 or RS485 protocol can be used on this jack, but not both at the same time. The RS485 OUT jack is used to daisy chain multiple QConnect devices together.

The DRY CONTACTheader is used for making connection with external dry contact sources such as Normally Open Relays or Normally Open Switches. A temporary closure of any combination of bits 1 thru 4 (refer to diagram) is decoded by the QConnect as a request for the corresponding button code to be transmitted by the QConnect.

SELECTING THE INTERFACE (RS232, RS485, DRY CONTACT)

The QConnect Bridge comes from the factory set for RS232 operation.

To change the mode to RS485, follow these steps:

- a) Unplug the power supply
- b) Hold the DOWN button
- c) Still holding the DOWN button plug the power supply back in

To change the mode to Dry Contact, follow these steps:

- d) Unplug the power supply
- e) Hold the UP button
- f) Still holding the UP button plug the power supply back in

To change the mode to RS232, follow these steps:

- g) Unplug the power supply
- h) Turn the rotary switch to '0'
- i) Plug the power supply back in

RS232 OPERATION

The QMotion QConnect RS232 interface uses the following settings:
9600 BAUD, 8 Data Bits, 1 Stop Bit, No Parity

A communication packet consists of the following data:

15 channel ID's.
Button code 0-F
LRC checksum

Each packet command to the bridge should include

- a) SOF
- b) Length
- c) Command ID
- d) Bridge ID
- e) Channel ID
- f) Button Code
- g) Reserved
- h) Checksum

Note: There is a Windows Application that will build the packet for you and display exactly what the packet should look like. The program can be downloaded from our website at www.qmotionshades.com/qconnecttester.php
(In RS232 operation mode interface channel ID should be set to 0x01 packet d) in the above format)

Field Description

SOF Start Of Frame. Used for synchronization and is equal to 0x01

Length Number of bytes in the frame, exclusive SOF and Checksum. The host application is responsible for entering the correct length field.

Command ID

0x01: Request product info;
0x02: Factory Reset sets the channel address values back to factory values;
0x03: Request Address Information, returns the value of the requested channel;
0x04: Assign Address Information, assigns a value to selected channel address;
0x05: Emit Button Code, sends a command to the shades

Bridge ID Number that the rotary switch is set to on a particular QConnect.

Channel ID Unique channel ID 0x01 – 0x0F for the selection of a particular channel (serial) to be transmitted via 433Mhz RF.

Button Code Unique button code ID 0x01 – 0x0F for the activation of a shade function. (see appendix A for list of valid button codes)

Checksum LRC checksum used to check for frame integrity. Checksum calculation includes the **Length, Type, Command ID, 0x00, Channel ID, Button Code** fields. The Checksum is a XOR checksum with an initial checksum value of 0xFF.

Example Packet Sending the shade to the open position using channel 15(decimal) and Bridge 1.

Packet	Sent Command From Host System	Returned Command From QConnect
Start of Frame	0x01	0x01
Length	0x07	0x07
Type	0x00	0x01
Command ID	0x05	0x05
Bridge ID	0x01	0x01
Channel ID	0x0F	0x0F
Button Code	0x01	0x01
Reserved(0x00)	0x00	0x00
Checksum	0xF7	0xF6

RS485 OPERATION

The QMotion QConnect RS485 interface uses the following settings:
9600 BAUD, 8 Data Bits, 1 Stop Bit, No Parity

A communication packet consists of the following data:

15 channel ID's.
15 interface ID's
Button code 0-F
LRC checksum

The baud rate for RS232 and RS485 operation will be, 4800 baud, 8 data bits, 1 stop bit, No parity

Each packet command to the bridge should include

- a) SOF
- b) Length
- c) Type
- d) Command ID
- e) Interface ID
- f) Channel ID
- g) Button Code
- h) Reserved
- i) Checksum

Note: There is a Windows Application that will build the packet for you and display exactly what the packet should look like. The program can be downloaded from our website at www.qmotionshades.com/qconnecttester.php

Field Description

SOF Start Of Frame. Used for synchronization and is equal to 0x01

Length Number of bytes in the frame, exclusive SOF and Checksum. The host application is responsible for entering the correct length field.

Type Used to distinguish between unsolicited calls and immediate responses (not callback). The request (REQ) is equal to 0x00 and response (RES) is equal to 0x01.

Command ID

0x01: Request product info;

0x02: Factory Reset sets the channel address values back to factory values;

0x03: Request Address Information, returns the value of the requested channel;

0x04: Assign Address Information, assigns a value to selected channel address;

0x05: Emit Button Code, sends a command to the shades

Interface ID Unique interface ID 0x01 – 0x0F for the selection of particular addressed bridge device on RS485 chain (selected by the rotary switch on each bridge).

Channel ID Unique channel ID 0x01 – 0x0F for the selection of a particular channel (serial) to be transmitted via 433Mhz RF.

Button Code Unique button code ID 0x01 – 0x0F for the activation of a shade function. (see appendix A for list of valid button codes)

Checksum LRC checksum used to check for frame integrity. Checksum calculation includes the **Length, Type, Command ID, Interface ID, Channel ID, Button Code** fields. The Checksum is a XOR checksum with an initial checksum value of 0xFF.

Reserved 0x00.

Example Packet Sending the shade to the closed position using channel 10(decimal) and bridge number 2.

Packet	Sent Command From Host System	Returned Command From QConnect
Start of Frame	0x01	0x01
Length	0x07	0x07
Type	0x00	0x01
Command ID	0x05	0x05
Interface ID	0x02	0x02
Channel ID	0x0A	0x0A
Button Code	0x02	0x02
Reserved(0x00)	0x00	0x00
Checksum	0xF7	0xF6

The outermost pair of pins on the 10 pin connector (nearest the edge of the QMotion QConnect) is used to enable the RS485 internal terminator. When daisy-chaining multiple Bridges together using the RS485 interface, the first device (usually the initiator, PC interface, controller) will have termination enabled, and only the last physical device in the daisy chain will have termination enabled. For instance if three QMotion QConnect devices are daisy chained together, only the last Bridge on the chain will have the terminator enabled.

DRY CONTACT OPERATION

The dry contact interface allows for external contact closures such as those from relay contacts to initiate RF commands.

The QMotion QConnect has four (4) pairs of male header pins which can be used to wire in contact control signals. The dry contact interface provides its own source power for making contact closure determination. A low impedance path established by an external switch or relay can be sensed by the Bridge and will initiate an RF command equivalent to the binary value of the contact input. For instance a contact closure of the input pins associated with “bit1” will cause binary button code 0001 (1 Decimal, 0x01 hex) to be transmitted. Contact closure of the input pins “bit3” and “bit1” will cause binary button code 0101 (5 decimal, 0x05 hex) to be transmitted. Please refer to APPENDIX A for button code values.

The upper row of pins are connected to the lower pins in the same bit column via the 3rd party device. The recommended closure time for a command is 2 seconds (less will work), the 3rd party device does not need to hold the closure until the window treatment has completed its travel. For instance, the 3rd party device connects the upper pin of bit column 1 to the lower pin of bit column 1 for 3 seconds, the window treatments in that group selected on the rotary dial will close. If total control of the group is needed via contact closure then 4 3rd party contact closure devices will be needed.

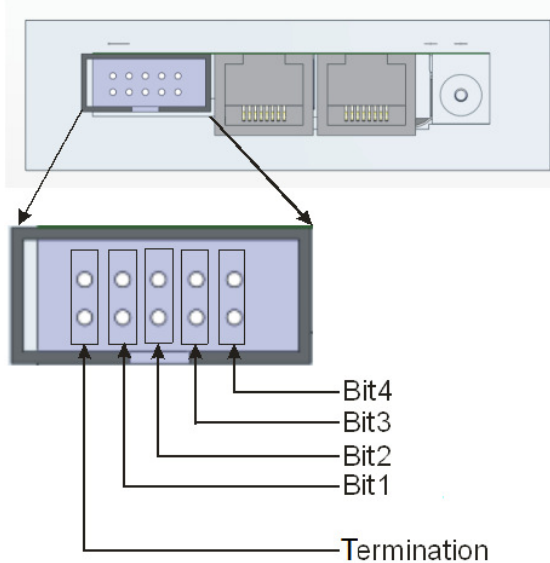

The “Termination” pins are not used for the contact closure function.

The Contact Closure Interface consists of a 10pin 0.100” pitch male header that is keyed.

The Contact interface allows for sensing contact closure as commands for sending out RF commands. The bit pairs indicated above (bit1 thru bit4) can be used individually or in combinations to make 16 different dry contact events.

You will need at least 2 relays for basic functions and 4 relays for all the functions to be available to the project. The group that will be controlled is set via the rotary dial, only 1 group can be controlled via contact closure.

EG:

To open the blinds in group 2 you will need to momentarily close the relay connected to “Bit 1” and have the rotary dial on the front set to #2.

To Close the blinds in group 2 you will need to momentarily close the relay connected to “Bit 2” and have the rotary dial on the front set to #2

FUNCTION	BUTTON CODE (DECIMAL)	BUTTON CODE (HEX)
BUTTON_FUNCTION3	0	0x00
BUTTON_UP	1	0x01
BUTTON_DOWN	2	0x02
BUTTON_FUNCTION1	3	0x03
BUTTON_SETPOINTA	4	0x04
BUTTON_FUNCTION2	5	0x05
BUTTON_PRESET1	6	0x06
BUTTON_PRESET2	7	0x07
BUTTON_SETPOINTB	8	0x08
BUTTON_PRESET3	9	0x09
BUTTON_PRESET4	10	0x0A
BUTTON_PRESET5	11	0x0B
BUTTON_SETPOINTC	12	0x0C
BUTTON_PRESET6	13	0x0D
BUTTON_PRESET7	14	0x0E
BUTTON_RESERVED	15	0x0F

A suitable mating connector such as WSW Components AWP10-7540-T-R or equivalent may be used to interface the QConnect Dry Contact Jack.

Note: Set point A is represents the initial 25% set point on a QMotion shade, Set point B is the initial 50% set point on a QMotion shade, and Set point C is the initial 75% set point on a QMotion shade. All three can be mapped to user specific locations on the shade, after they are mapped the bridge will send the shades to the user picked positions when Set point A, B, or C are sent out

BATTERY POWERED OPERATION

While on battery power the QConnect functions as a standard remote with an up button and a down button. Battery powered operation is intended to be used to learn the QConnect to your installed QMotion shades.

To learn the QConnect to your QMotion shades:

- a) Unplug the QConnect from the power supply and bring it to the shade you would like to control with the QConnect.
- b) Using the Rotary Switch set the QConnect to the appropriate channel you would like to control the shade (1- F).
- c) Using a remote that is already learned to the shade press the up button and wait for the shade to move to the open position (shade is rolled up)
- d) After the shade stops at the top press and hold the Up button until the shade begins to move down (hold for roughly 5 seconds) and release the button. The shade should stop at the 75% closed position.
- e) Manually tug the shade
- f) Now press and hold the up button on the QConnect until the shade moves to the full open position. Your QConnect is now learned to the shade on the channel designated by the rotary switch.

Revisions

Rev. 0.1	B. Garcia 10/5/2011 initial release
Rev. 0.2	B. Garcia 10/6/2011 corrections/additions
Rev. 0.3	B. Garcia 10/6/2011 additions
Rev. 0.4	J. Watts 10/6/2011 additions
Rev. 0.5	J. Watts 10/6/2011 additions
Rev. 0.6	D. Ayers 10/18/2011 additions
Rev. 0.7	J. Watts 10/19/2011 additions
Rev. 0.8	J. Watts 11/2/2011 corrections
Rev.0.9	G Wuthrich 11/3/2011
Rev.0.10	J.Watts 12/19/2011 added Windows App link
Rev.1.0	J. Watts 3/13/2012 additions
Rev.1.1	J.Watts 8/7/2012 additions
Rev.1.2	J.Watts 9/13/2012 additions
Rev.1.3	J.Watts 12/18/2012 corrections
Rev.1.4	J.Watts 1/22/2013 corrections
Rev.1.5	Michael Dalton 2/5/2014, simplification and reordering