

SONANCE

PROFESSIONAL SERIES SURFACE MOUNT SUBWOOFER

PS-S10SUBT



SONANCE PROFESSIONAL SERIES

From Sonance, the company that created the architectural audio category comes a range of professional loudspeakers that set a new benchmark in sound quality and aesthetics for commercial environments.

Sonance Professional Series includes a range of In-Ceiling, Pendant and Surface Mount Speakers that deliver unequalled fidelity, extremely low distortion, wide dispersion and a smooth power response. The range also shares consistent voicing, ensuring seamless sonic integration when used together throughout a space.

APPLICATIONS

- Shopping Malls, Retail Spaces & Showrooms
- Restaurants, Bars & Lounges
- Galleries, Museums & Amusement Parks
- Casinos, Convention Centers & Hotels
- Houses of Worship & Educational Facilities
- Sporting Facilities

SURFACE MOUNT PS-S10SUBT SUBWOOFER

FEATURES AND BENEFITS

- Dual 10" drivers - specifically designed and engineered in-house by Sonance for this application
- Low profile design - designed to go under banquetts, booths, furniture with supplied feet or mounted on rafters, walls and ceilings with optional C-Bracket
- Port can be moved from front to side by swapping the blank plate, ensuring optimum sonic performance in any location
- Sonance Laminated Core Technology transformer (SLCT) - Full-fidelity performance in 70V/100V
- Built-in low pass filter (crossover)
- The combination of the transformer and bandpass filter allows the PS-S210SUBT to be driven on the same line as the other full-range speakers in a system; eliminating the need for dedicated amplifier channel with DSP
- Removable grille to keep enclosure free of foreign objects
- Side connector cover with cable management

DIMENSIONS

PS-S10SUBT

SKU#: 40192
Width: 33" (838mm)
Height: 8.98" (228mm)
Depth: 13.78" (350mm)

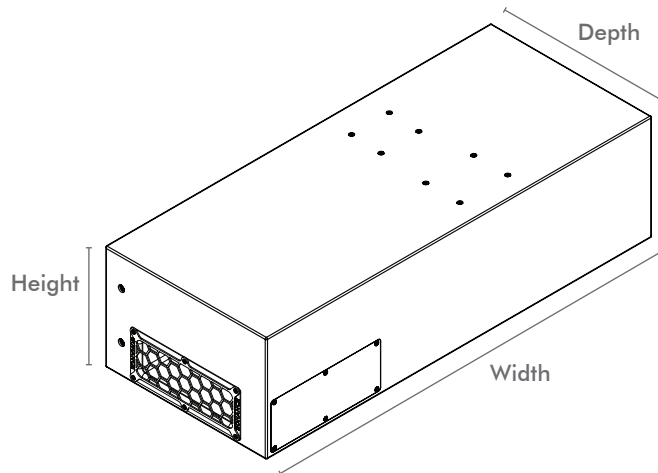

TECHNICAL SPECIFICATIONS

Frequency Range	(-10dB) 34Hz - 155hz
Frequency Range	(-3dB) 44Hz - 132Hz
Power Capacity	500 Watts Continuous Program Power 300 Watts Continuous Pink Noise
Nominal Sensitivity*	94 dB
Nominal Coverage Angle	180 degrees conical coverage
Rated Maximum SPL*	121dB @ 1 meter (3.3 feet) average, 127dB peak
Rated Impedance	4 ohms nominal, 3.7 ohms minimum
Transformer Taps	300W, 150W, 75W and (37W @70V)
Crossover Point	150Hz low pass filter, 12dB/octave
Transducers: LF Driver	Dual 10" (254mm) Woven glass fiber cones, Butyl rubber surrounds
Input Connectors	Four pin Euroblock with loop output connections
Included Accessories	Euroblock connector, terminal cover & screws, installation manual, rubber feet
Overall Dimension HxWxD	8.98" x 33.00" x 13.78" (228mm x 838mm x 350mm)
Net Weight	61 lbs (27.7kg) each
Shipping Weight	75.8 lbs (33.0kg) each
Optional Accessories	C-Bracket (PN: 40194)
Included Accessories	Euroblock connector, (4) M10 mounting bolts, installation manual, rubber feet

*Half Space (2π)

DIMENSIONS

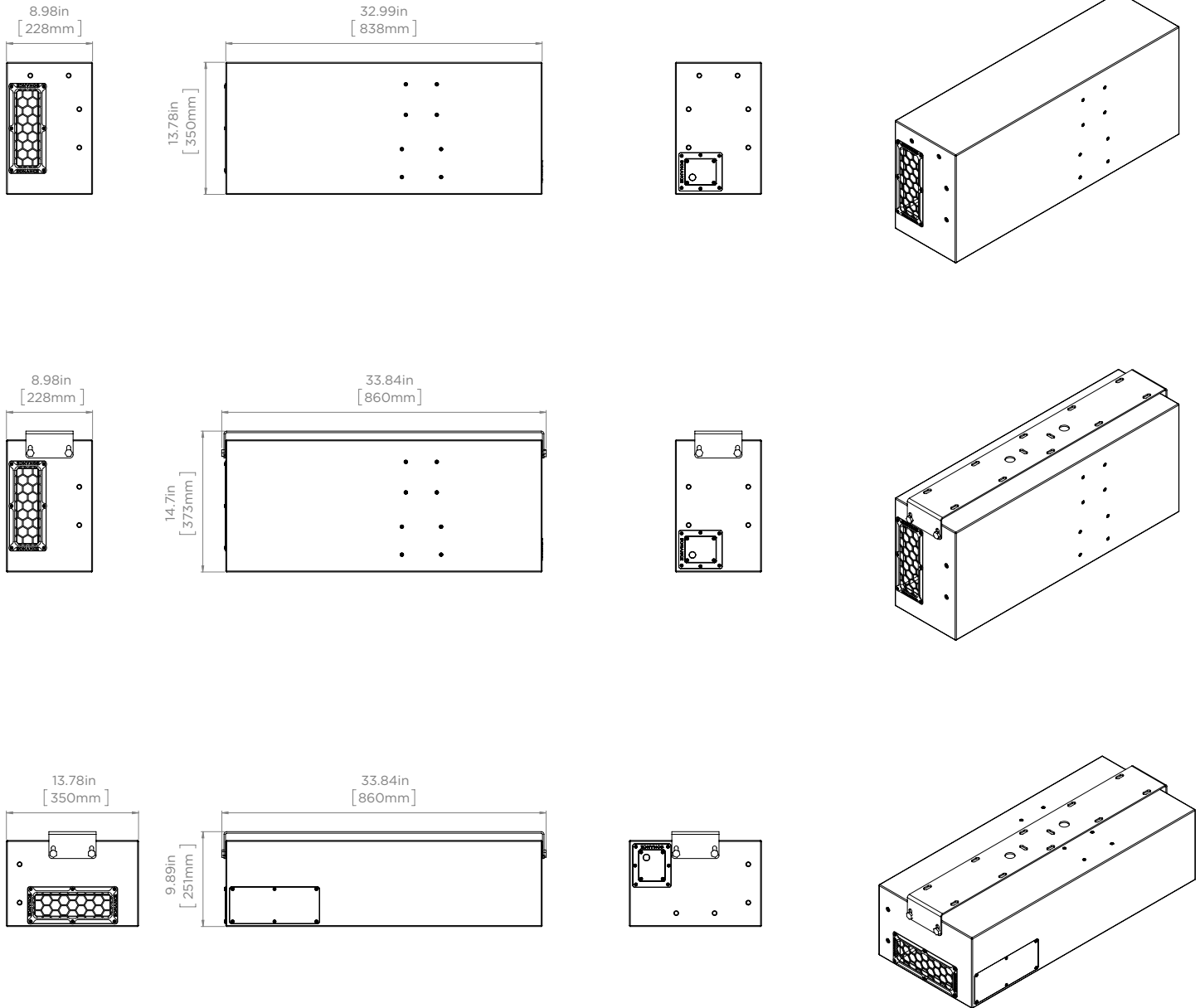

ASSOCIATED PRODUCTS

IN-CEILING SPEAKERS

PS-C43RT In-Ceiling Speaker	40130
PS-C63RT In-Ceiling Speaker	40131
PS-C83RT In-Ceiling Speaker	40132
PS-C83RWT In-Ceiling Speaker	40133

PENDANT SPEAKERS

PS-P43T Pendant Speaker White	40134
PS-P63T Pendant Speaker White	40135
PS-P83T Pendant Speaker White	40136
PS-P83WT Pendant Speaker White	40137
PS-P43T Pendant Speaker Black	40138
PS-P63T Pendant Speaker Black	40139
PS-P83T Pendant Speaker Black	40140
PS-P83WT Pendant Speaker Black	40141

SURFACE MOUNT SPEAKERS

PS-S43T Surface Mount Speaker White	40142
PS-S53T Surface Mount Speaker White	40143
PS-S63T Surface Mount Speaker White	40144
PS-S83WT Surface Mount Speaker White	40146
PS-S43T Surface Mount Speaker Black	40147
PS-S53T Surface Mount Speaker Black	40148
PS-S63T Surface Mount Speaker Black	40149
PS-S83WT Surface Mount Speaker Black	40151

DSP AMPLIFIER

Sonamp DSP 2-750 MKII Amplifier	93379
---------------------------------	-------

ARCHITECTURAL SPECIFICATIONS

The loudspeaker shall be a subwoofer comprising a polyurethane coated, laminated plywood enclosure containing two 10" (254mm) low profile, woven glass fiber cone with Butyl with rubber surround, ultra-high excursion low frequency transducers. Frequency range shall be 44Hz - 132Hz (-3dB). Total power handling shall be 300 Watts continuous pink noise and 500 Watts program. Sensitivity measured with 2.83 volts input at 1 meter on axis averaged between 44Hz - 132Hz shall be 94dB. The unit shall be supplied with a line-matching transformer suitable for 100 volt or 70 volt with a side-mounted control allowing user selectable power taps of 300W, 150W, and 75W (70V) and an 8 Ohm bypass. It shall include an integrated low-pass filter. The speaker shall be supplied with feet, and an optional metal C-Bracket should be available with fitment on two sides of the enclosure via 8 x M10 female-threaded blind rigging points. Wire shall be terminated on the side of the enclosure via a four-pin Euroblock connector with loop-through with a cover. External dimensions shall be 9" height x 33" width x 13.78" deep (228mmx 838mm x 350mm) and it shall weigh 61 lbs. (22.7 kg) per unit. It shall feature the ability to port sound through either the front or the side of the enclosure to ensure and have a removable port grille. The loudspeaker shall be the Sonance Professional Series PS-S210SUBT. No other system shall be acceptable unless the above combined performance specifications are equaled or exceeded.

TECHNICAL ASSISTANCE AND SERVICE

The Technical Assistance Department at Sonance is available at (949) 492-7777 to answer any questions concerning the operation and installation of your speakers between the hours of 7:00 AM and 5:00 PM Pacific time, Monday through Friday, except holidays.

In the event your unit should need repair or service, you may return the unit to your authorized dealer or use the following guidelines:

PLEASE KEEP ORIGINAL PACKAGING WHEN POSSIBLE.

1. Be prepared to state the model number and / or serial number, date of purchase, and dealer's name and address when calling.
2. Contact Sonance directly at (949) 492-7777 or at www.sonance.com. **YOU MUST HAVE PRIOR AUTHORIZATION TO RETURN YOUR UNIT.**
3. If you are returning the product directly to Sonance, call us to obtain a return authorization number before shipping.
4. Ship the product via United Parcel Service, Federal Express, or other package delivery service. Please do not use the U.S. Postal Service.
5. Include the return authorization number on the shipping label.
6. Ship to:

Attn: Quality Assurance Department,
RMA#(include RMA number here)
Sonance
11016 Mulberry Ave.
Suite B
Fontana, CA 92337

POLAR RESPONSE PLOTS

RATIO vs ANGLE (VERTICAL)

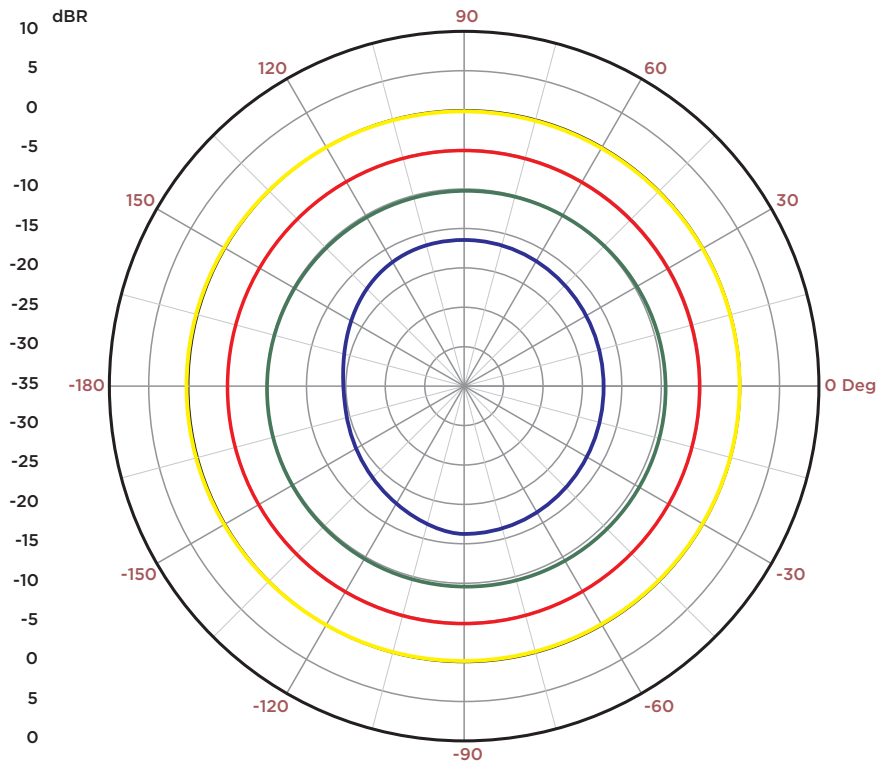

CURVE	FREQ.	BW	Q	DI
— (Red)	40	360	1.0	0.0
— (Yellow)	80	360	1.0	0.0
— (Green)	160	360	1.0	0.0
— (Blue)	315	360	1.0	0.0

RATIO vs ANGLE (HORIZONTAL)

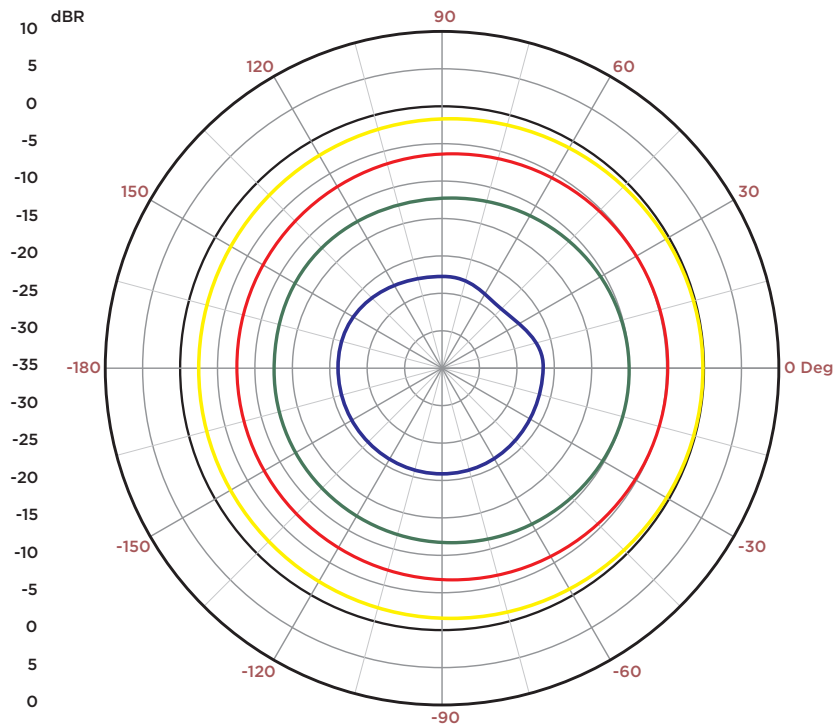

CURVE	FREQ.	BW	Q	DI
— (Red)	40	360	1.0	0.0
— (Yellow)	80	360	1.0	0.0
— (Green)	160	360	1.0	0.0
— (Blue)	315	360	1.0	0.0

DIRECTIVITY INDEX

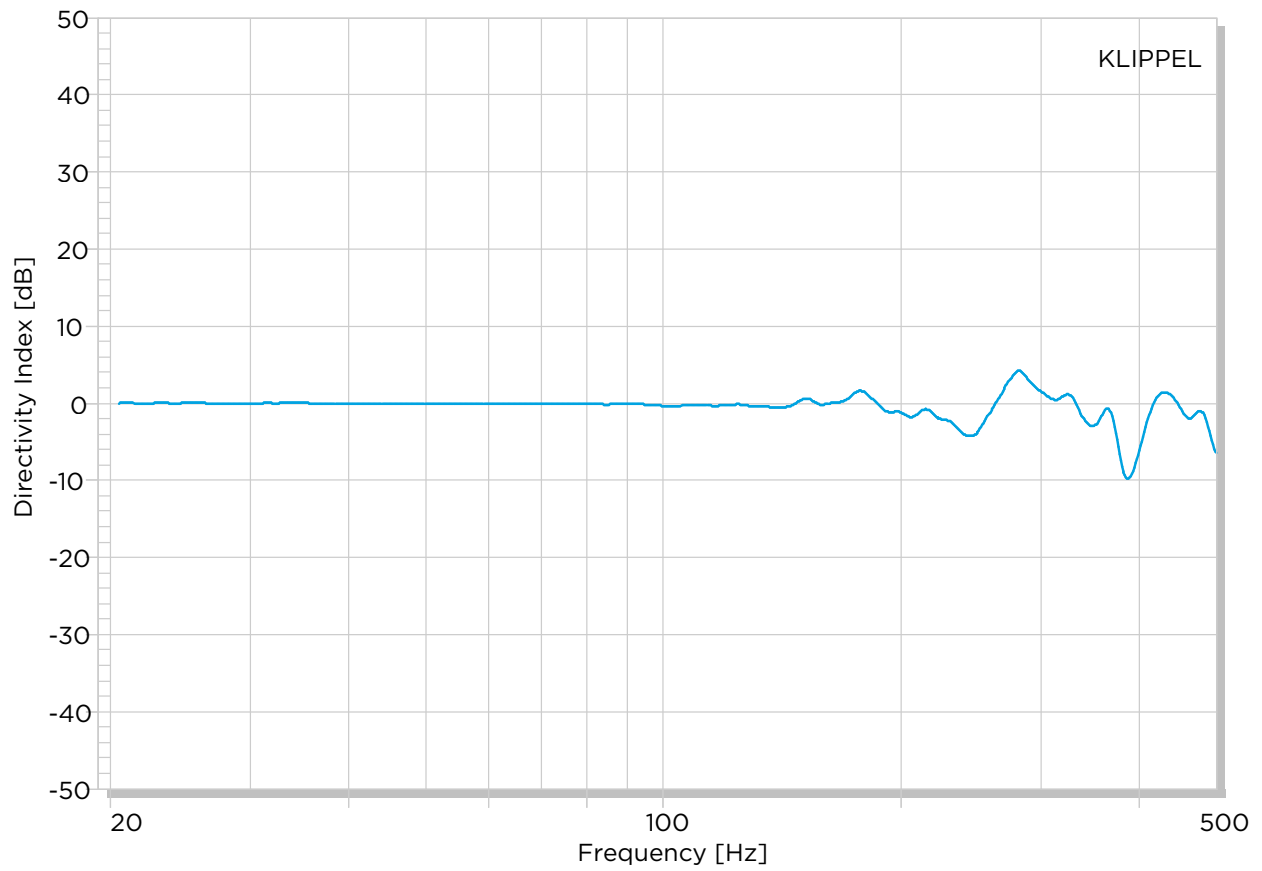

RADIATED SOUND POWER

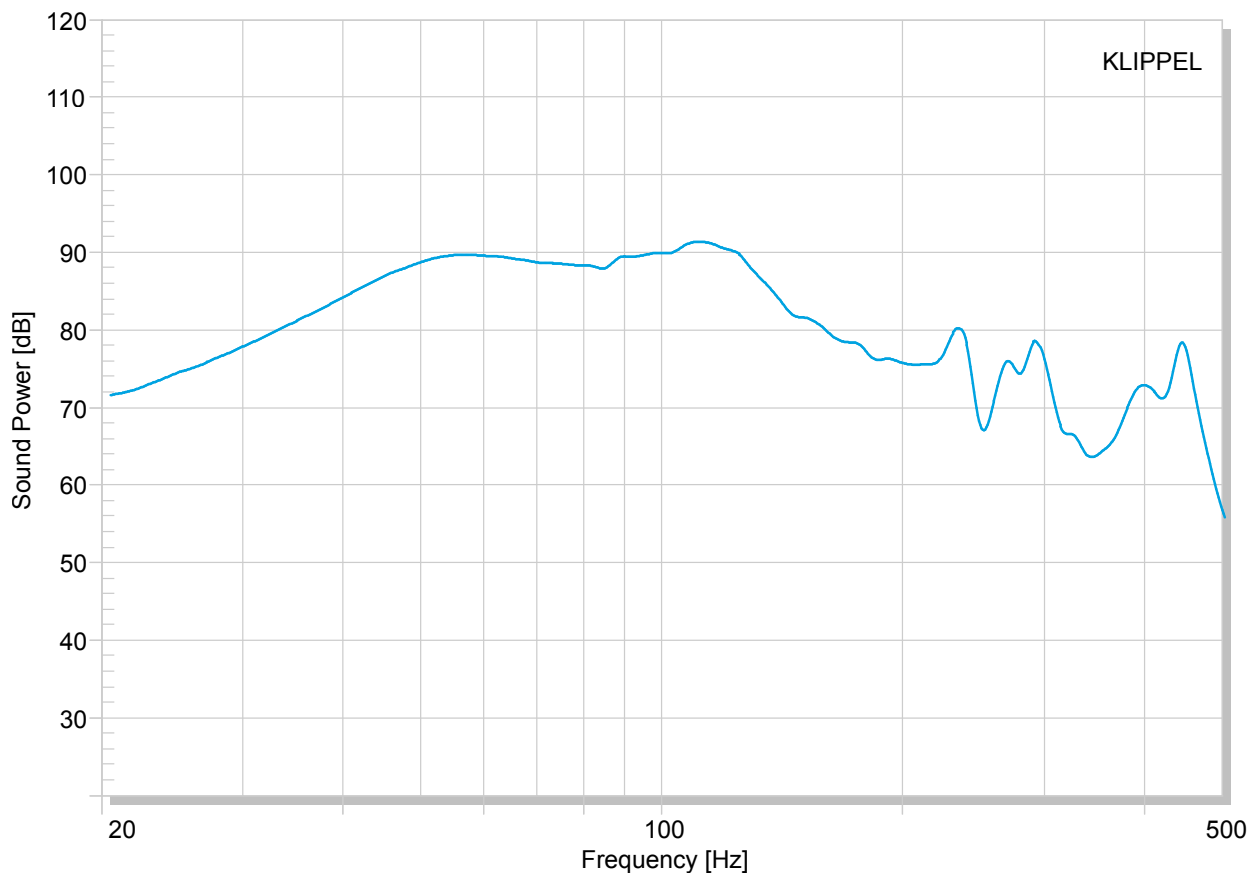

LIMITED FIVE (5) YEAR WARRANTY

Sonance warrants to the first end-user purchaser that this Sonance-brand product (“Product”), when purchased from an authorized Sonance Dealer/Distributor, will be free from defective workmanship and materials for the period stated below. Sonance will at its option and expense during the warranty period, either repair the defect or replace the Product with a new or remanufactured Product or a reasonable equivalent.

EXCLUSIONS

TO THE EXTENT PERMITTED BY LAW, THE WARRANTY SET FORTH ABOVE IS IN LIEU OF, AND EXCLUSIVE OF, ALL OTHER WARRANTIES, EXPRESS OR IMPLIED, AND IS THE SOLE AND EXCLUSIVE WARRANTY PROVIDED BY SONANCE. ALL OTHER EXPRESS AND IMPLIED WARRANTIES, INCLUDING THE IMPLIED WARRANTIES OF MERCHANTABILITY, IMPLIED WARRANTY OF FITNESS FOR USE, AND IMPLIED WARRANTY OF FITNESS FOR A PARTICULAR PURPOSE ARE SPECIFICALLY EXCLUDED.

No one is authorized to make or modify any warranties on behalf of Sonance. The warranty stated above is the sole and exclusive remedy and Sonance’s performance shall constitute full and final satisfaction of all obligations, liabilities and claims with respect to the Product.

IN ANY EVENT, SONANCE SHALL NOT BE LIABLE FOR CONSEQUENTIAL, INCIDENTAL, ECONOMIC, PROPERTY, BODILY INJURY, OR PERSONAL INJURY DAMAGES ARISING FROM THE PRODUCT, ANY BREACH OF THIS WARRANTY OR OTHERWISE.

This warranty statement gives you specific legal rights, and you may have other rights which vary from state to state. Some states do not allow the exclusion of implied warranties or limitations of remedies, so the above exclusions and limitations may not apply. If your state does not allow disclaimer of implied warranties, the duration of such implied warranties is limited to period of Sonance’s express warranty. Your Product Model and Description: PS-S210SUBT. Warranty Period for this Product: Five (5) years from the date on the original sales receipt or invoice or other satisfactory proof of purchase. Additional Limitations and Exclusions from Warranty Coverage: The warranty described above is non-transferable, applies only to the initial installation of the Product, does not include installation of any repaired or replaced Product, does not include damage to allied or associated equipment which may result for any reason from use with this Product, and does not include labor or parts caused by accident, disaster, negligence, improper installation, misuse (e.g. overdriving the amplifier or speaker, excessive heat, cold or humidity), or from service or repair which has not been authorized by Sonance. Obtaining Authorized Service: To qualify for the warranty, you must contact your authorized Sonance Dealer/Installer or call Sonance Customer Service at (949) 492-7777 within the warranty period, must obtain a return merchandise number (RMA), and must deliver the Product to Sonance shipping prepaid during the warranty period, together with the original sales receipt, or invoice or other satisfactory proof of purchase.

SONANCE

©2019 Sonance. All rights reserved. Sonance is a registered trademarks of Dana Innovations. Due to continuous product improvement, all features and specifications are subject to change without notice. For the latest Sonance product specification information visit our website: www.sonance.com

SONANCE • 991 Calle Amanecer • San Clemente, CA 92673 USA
PHONE: (949) 492-7777 • FAX: (949) 361-5151 • Technical Support: (949) 492-7777 • www.sonance.com
01.15.2020