



### DESIGN HIGHLIGHTS

- Drop & Roll concealed flap mechanism gives neatest possible look
- Full cable management
- Mechanism can be sized to suit specific screen sizes
- Onboard electronics
- Wide range of mounting options

### OPTIONS

- Bang & Olufsen / Loewe mount option
- Swivel function available on PLS lift mechanisms
- B&O Beo4 control option

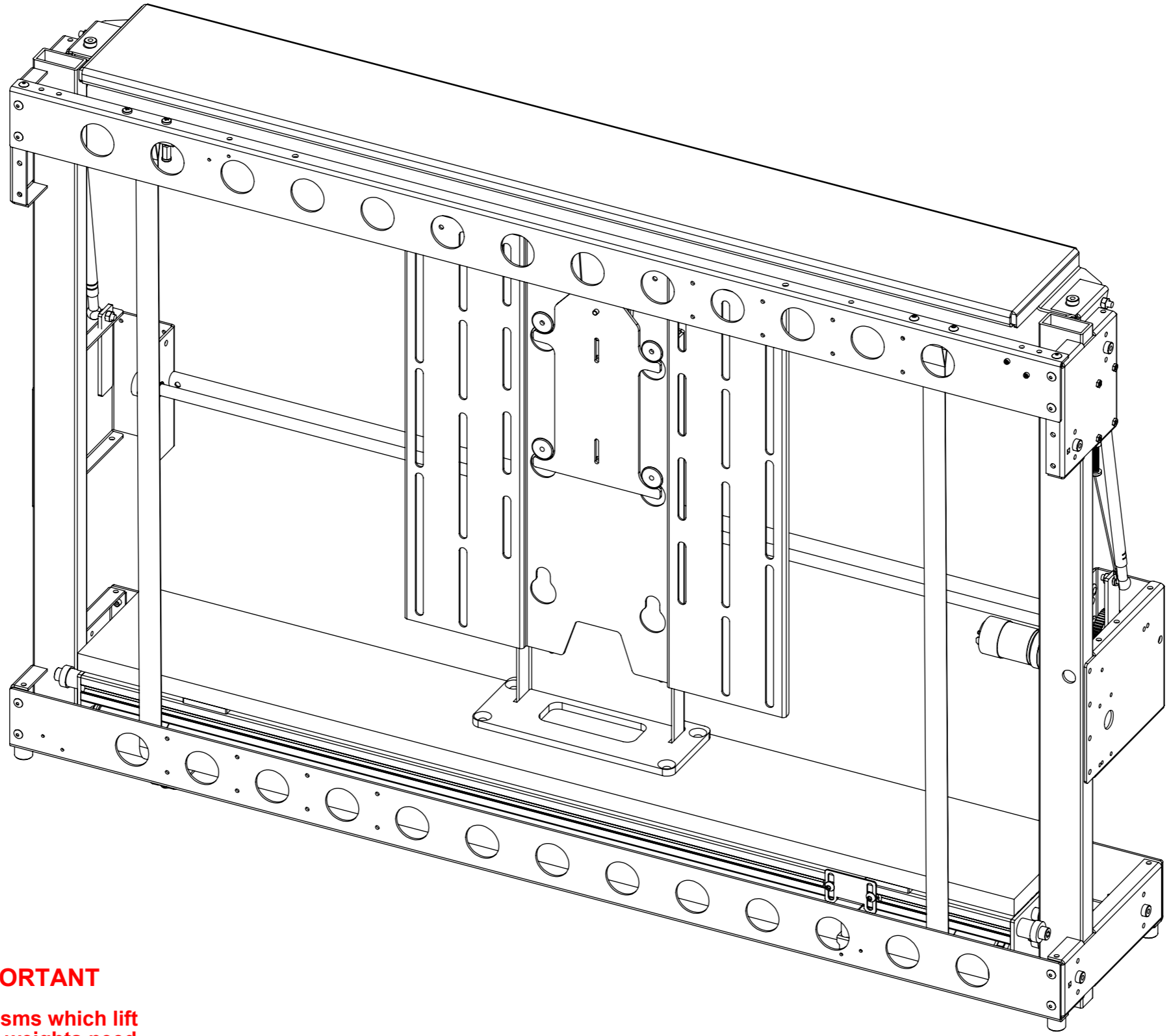

### FUNCTION

A flap is electrically opened and concealed with the cabinet before lifting the screen. This gives the neatest look of all the lift options.

An electrically swivelling mount can be an option to allow the screen to be viewed from multiple viewing areas.

### SUITABILITY

The PL range of lifts is suitable screens from 26" to 50" in size.

Maximum allowable screen weight is 50Kg (110lb).

There are eight heights, eleven widths and 3 depths to choose from, giving many size options.

### SPECIFYING

Choose the screen first.

Then work out cabinet dimensions.

Cabinet can be made while the mechanism is being made by Future Automation.

### CONTROL

Supplied with basic infrared remote. Can be learnt by many learning remotes.

Also has switch control and RS232 so can be operated by relays, switches, Crestron / AMX or Lutron systems.

### WARNING

It is the responsibility of the installer to warn all potential end users of the dangers of interfering with mechanisms during operation

### IMPORTANT

Mechanisms which lift or move weights need to be checked on a yearly basis for any damage which may result in an accident



## Design Highlights

The electric flap lowers down into the cabinet, approximately 40mm (1.5") before rolling back in the cabinet. The screen is then raised through the aperture in the cabinet top.

This method of flap movement gives the neatest possible look as there is no flap panel left visible once the screen is in the viewing position.

Once fully elevated, a base panel can be fitted to fill the aperture in the cabinet top.

Full cable management keeps all screen power and signal cables safe and secure during mechanism operation.

Many mounting options available for Loewe and Bang & Olufsen screens.

An advance control system allows the lift mechanism to be easily controlled via home automation systems such as Crestron and AMX. Two way communication is also possible via RS232.

With PLS mechanisms, up to 180° of movement is possible in both clockwise and counter clockwise directions.

With PLS mechanisms, up to four angular positions can be stored in the mechanisms memory via the IR remote control.

Many size options are available allowing the most efficient cabinet dimensions to be used for the chosen screen.

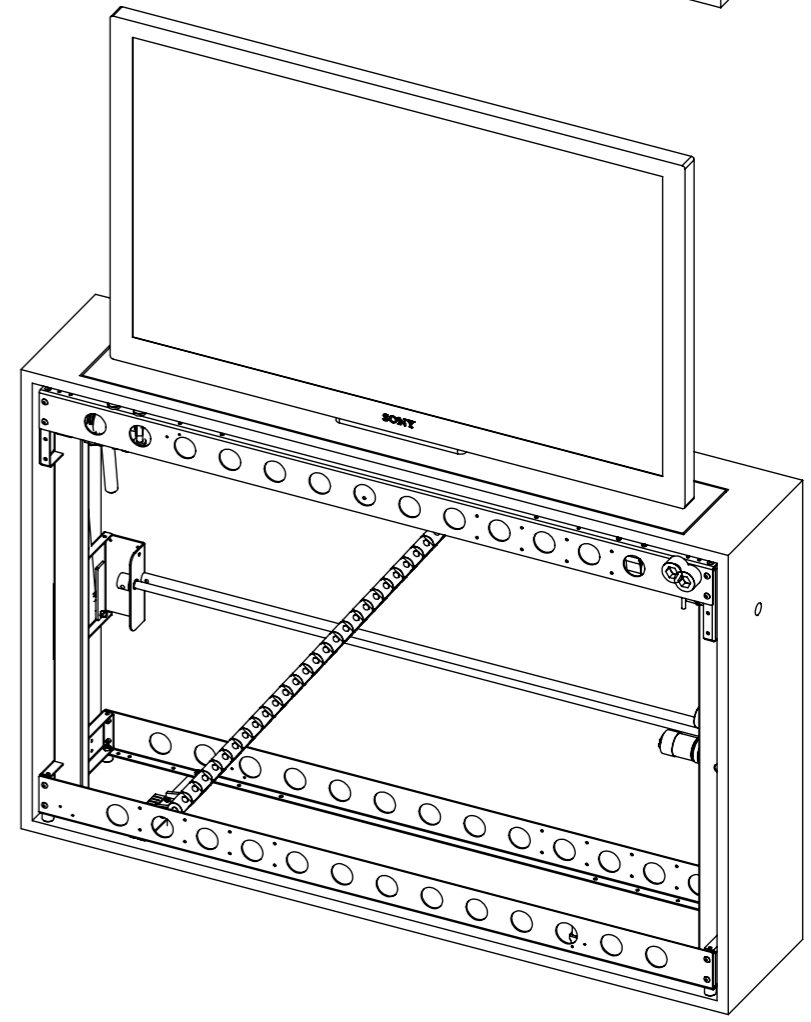
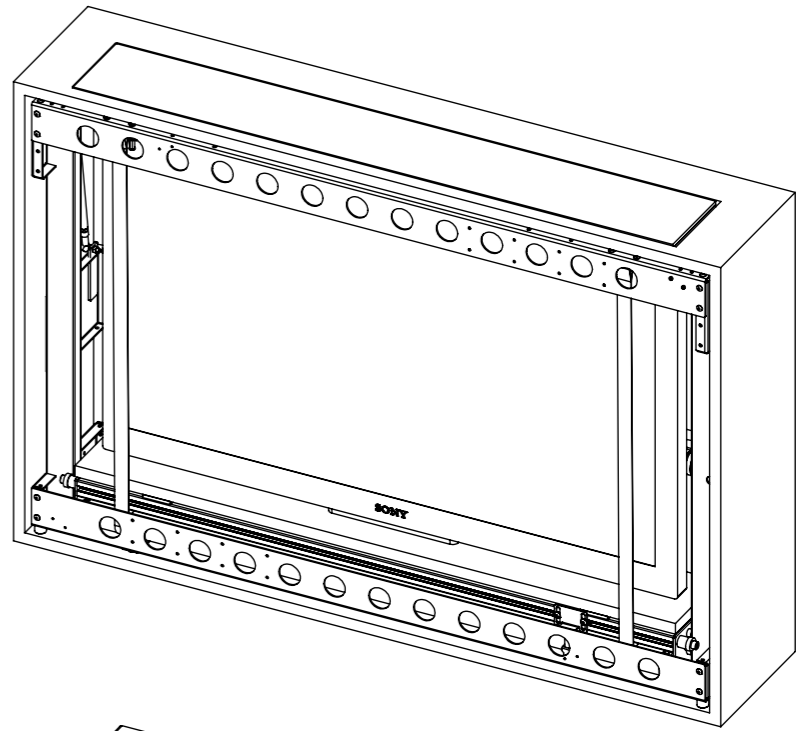
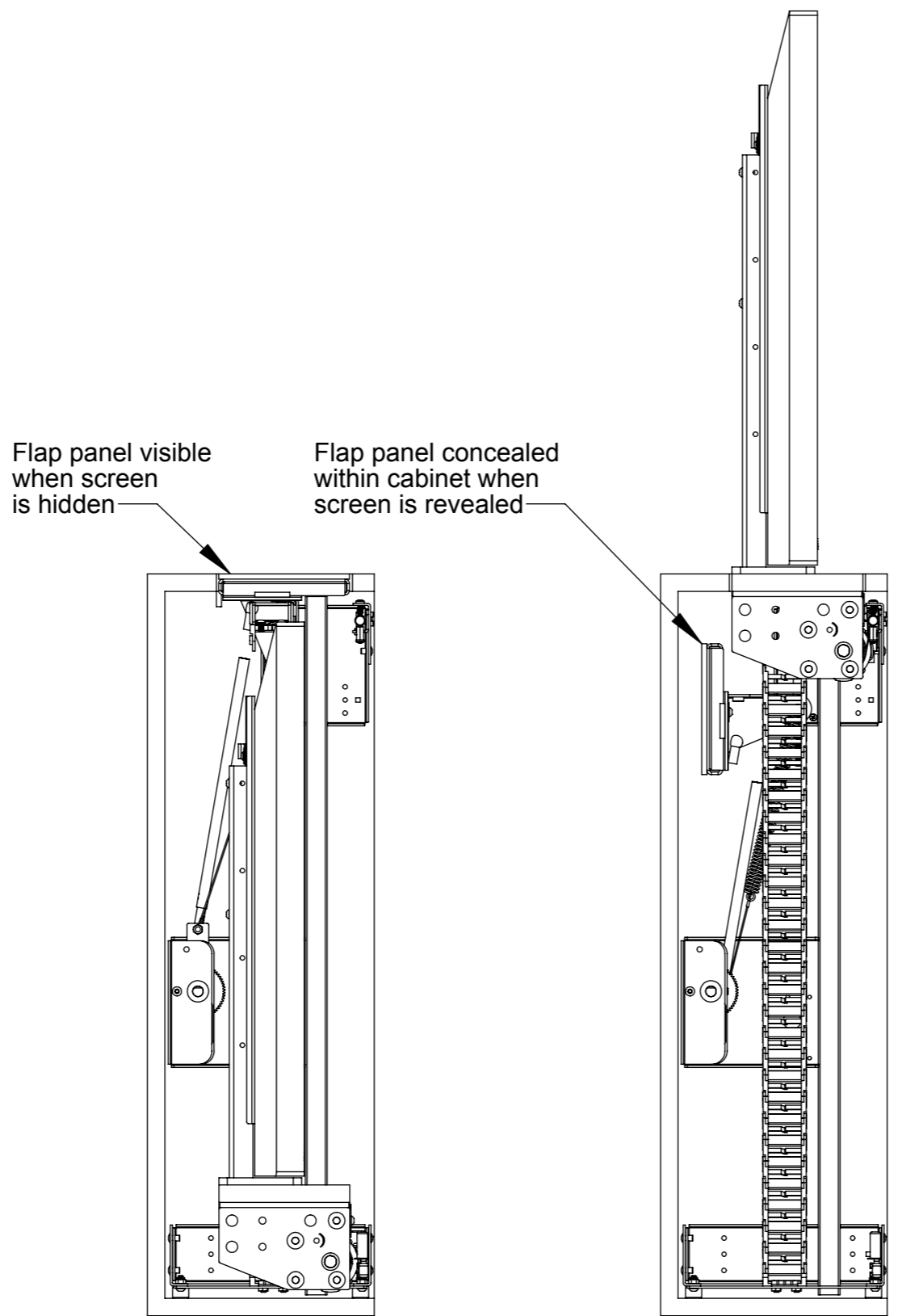

## Important Information

Start with screen size. Match the size of your screen to one of the 5 standard lift sizes. Make sure that you don't include the stand, as a suitable support framework will be supplied with the mechanism. Make sure the size includes any clip on speakers required.

The flap is only 6mm thick. This is bonded to an Aluminium section beneath supplied with the lift. This will help prevent warping. It is advisable to varnish both sides of the flap.

The base goes under the screen and will need holes drilled during installation for the support framework and screen cables.

The height and width are critical so make the cabinet to the exact size stated in the technical sheets. The lift mechanism will be slightly smaller than the sizes given. The depth of the cabinet can be increased.

Full front or back access is required in order to insert the mechanism within the cabinet.

For safety reasons it is advisable for the cabinet top to be held on only with dowels. This will allow the top to be lifted off if a hand is placed in the opening when the screen is lifting.

### Example of a Thicker Cabinet Top

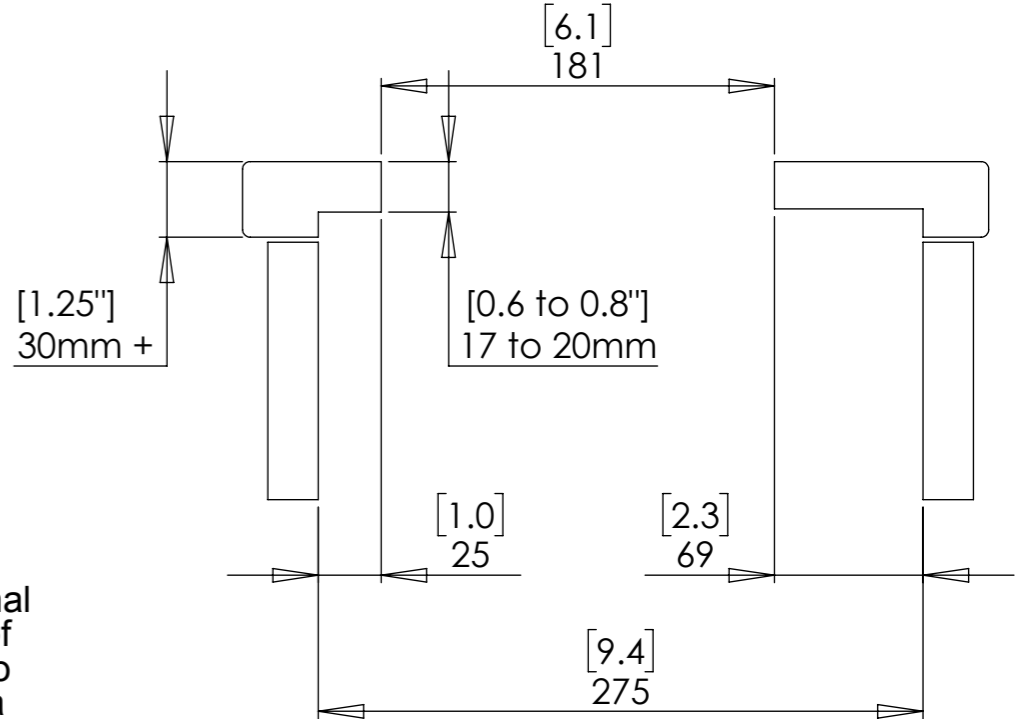

The PLS incorporates an additional swivel movement to the action of the screen. The screen is able to rotate about its centre through a maximum angle of 180° CW and Counter-CW.

The section above shows the use of a thicker cabinet top. This is possible but the top thickness around the mechanism must be no more than 17 to 20mm.

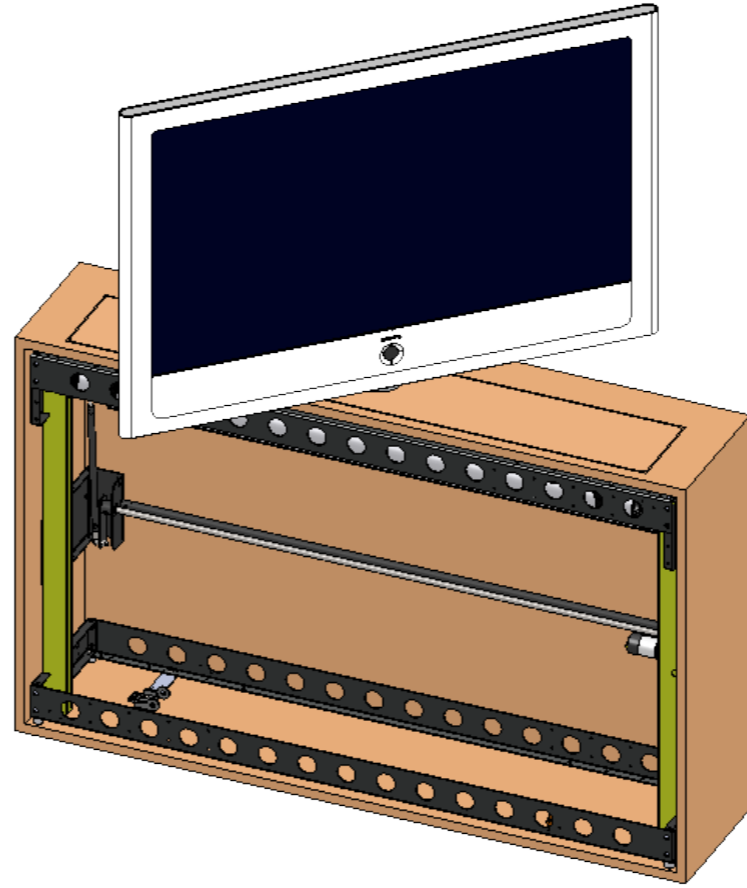

## PL Bespoke - Slim

Maximum screen thickness - 105mm [4.1"]  
Maximum screen weight - 50Kg [110lb]

Maximum flap panel weight - 4Kg [9lb]  
Maximum base panel weight - 6Kg [13lb]

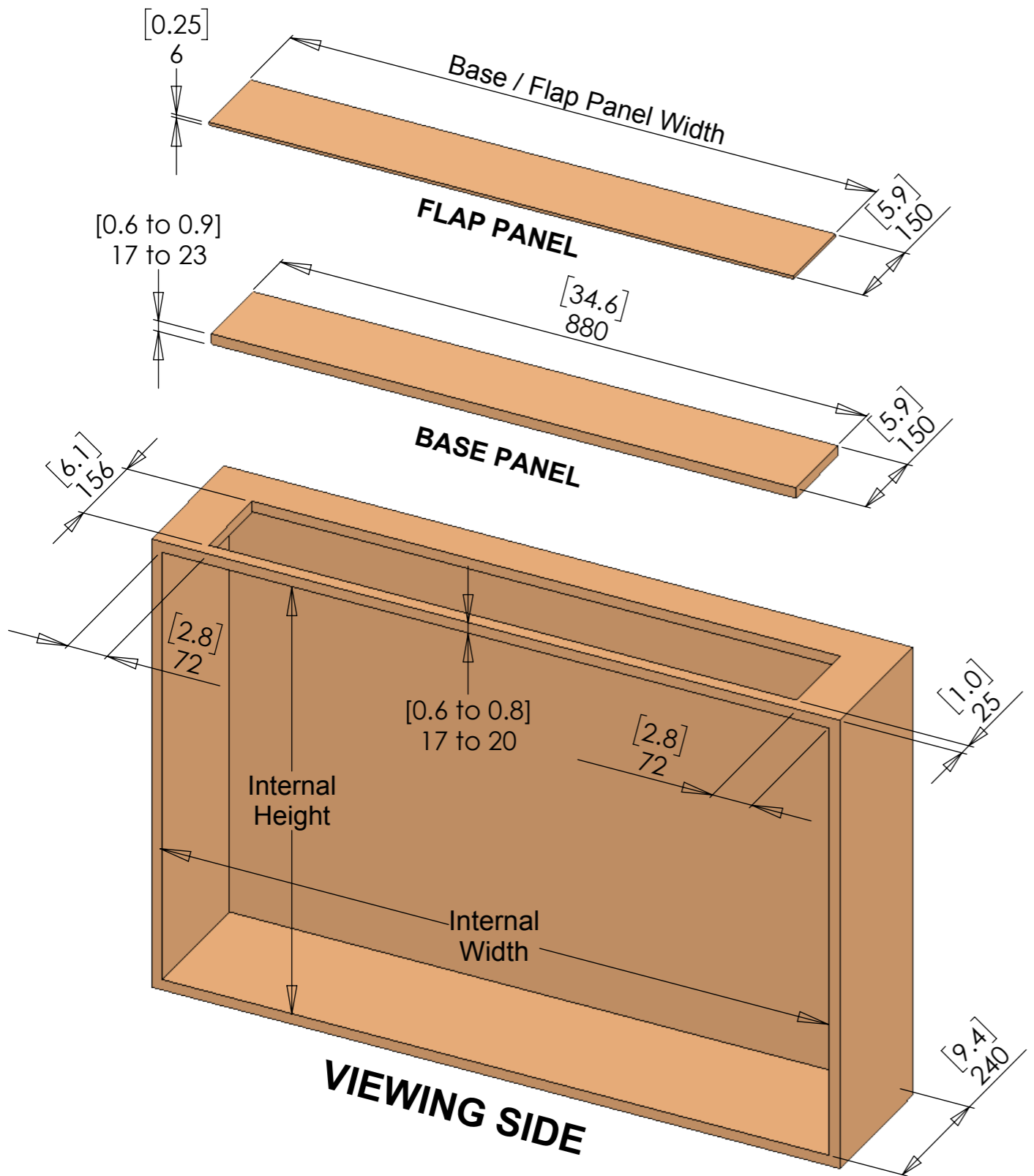

MAXIMUM SCREEN HEIGHT mm [inches]	MAXIMUM SCREEN HEIGHT FOR SWIVEL	INTERNAL HEIGHT mm [inches]
530 [20.9]	SWIVEL OPTION NOT AVAILABLE ON SLIM PL LIFT MECHANISMS	H 710 [28.0]
580 [22.8]		H 760 [29.9]
630 [24.8]		H 810 [31.9]
680 [26.8]		H 860 [33.9]
730 [28.7]		H 910 [35.8]
780 [30.7]		H 960 [37.8]
830 [32.7]		H 1010 [39.8]
880 [34.6]		H 1060 [41.7]

MAXIMUM SCREEN WIDTH mm [inches]	BASE / FLAP PANEL WIDTH mm [inches]	INTERNAL WIDTH mm [inches]
650 [25.6]	670 [26.4]	W 820 [32.3]
750 [29.5]	770 [30.3]	W 920 [36.3]
850 [33.5]	870 [34.3]	W 1020 [40.2]
950 [37.4]	970 [38.2]	W 1120 [44.1]
1050 [41.3]	1070 [42.1]	W 1220 [48.1]
1150 [45.3]	1170 [46.1]	W 1320 [52.0]
1250 [49.2]	1270 [50.0]	W 1420 [56.0]
1350 [53.1]	1370 [53.9]	W 1520 [59.9]
1450 [57.1]	1470 [57.9]	W 1620 [63.8]
1550 [61.0]	1570 [61.8]	W 1720 [67.7]
1650 [65.0]	1670 [65.7]	W 1820 [71.7]

## PL Bespoke - Deep

Maximum screen thickness - 130mm [5.1"]  
Maximum screen weight - 50Kg [110lb]

Maximum flap panel weight - 4Kg [9lb]  
Maximum base panel weight - 6Kg [13lb]

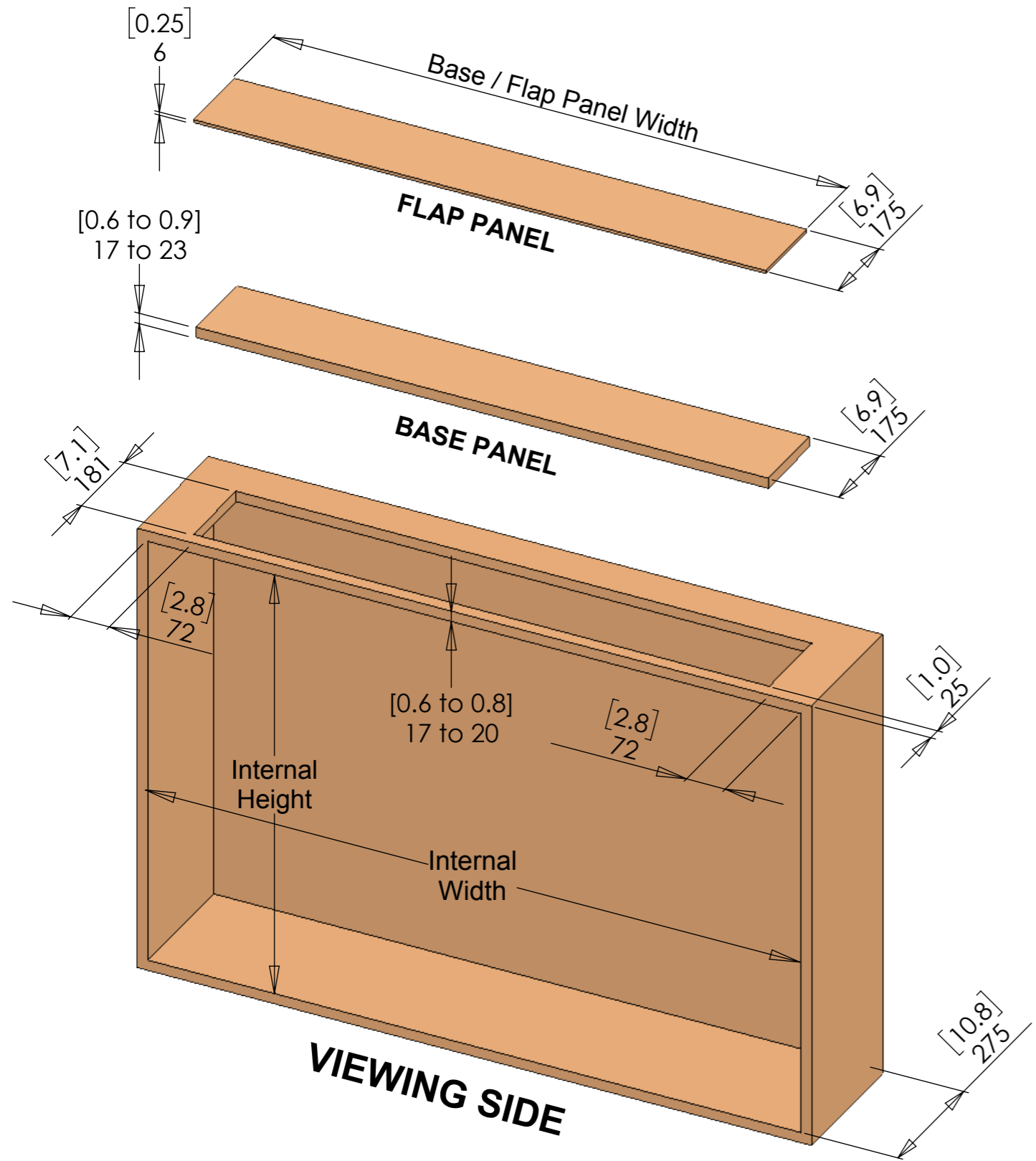

MAXIMUM SCREEN HEIGHT mm [inches]	MAXIMUM SCREEN HEIGHT FOR SWIVEL mm [inches]	INTERNAL HEIGHT mm [inches]
530 [20.9]	520 [20.4]	<b>H 710 [28.0]</b>
580 [22.8]	570 [22.4]	<b>H 760 [29.9]</b>
630 [24.8]	620 [24.4]	<b>H 810 [31.9]</b>
680 [26.8]	670 [26.3]	<b>H 860 [33.9]</b>
730 [28.7]	720 [28.3]	<b>H 910 [35.8]</b>
780 [30.7]	770 [30.3]	<b>H 960 [37.8]</b>
830 [32.7]	820 [32.2]	<b>H 1010 [39.8]</b>
880 [34.6]	870 [34.2]	<b>H 1060 [41.7]</b>

MAXIMUM SCREEN WIDTH mm [inches]	BASE / FLAP PANEL WIDTH mm [inches]	INTERNAL WIDTH mm [inches]
650 [25.6]	670 [26.4]	<b>W 820 [32.3] **</b>
750 [29.5]	770 [30.3]	<b>W 920 [36.3]</b>
850 [33.5]	870 [34.3]	<b>W 1020 [40.2]</b>
950 [37.4]	970 [38.2]	<b>W 1120 [44.1]</b>
1050 [41.3]	1070 [42.1]	<b>W 1220 [48.1]</b>
1150 [45.3]	1170 [46.1]	<b>W 1320 [52.0]</b>
1250 [49.2]	1270 [50.0]	<b>W 1420 [56.0]</b>
1350 [53.1]	1370 [53.9]	<b>W 1520 [59.9]</b>
1450 [57.1]	1470 [57.9]	<b>W 1620 [63.8]</b>
1550 [61.0]	1570 [61.8]	<b>W 1720 [67.7]</b>
1650 [65.0]	1670 [65.7]	<b>W 1820 [71.7]</b>

**IMPORTANT**  
When opting for a swivelling mechanism (PLS), maximum screen thickness is then reduced to 115mm [4.5"].

\*\* Swivel option NOT available with this width.



## PL Bespoke - Super Deep

Maximum screen thickness - 155mm [6.1"]  
Maximum screen weight - 50Kg [110lb]

Maximum flap panel weight - 4Kg [9lb]  
Maximum base panel weight - 6Kg [13lb]

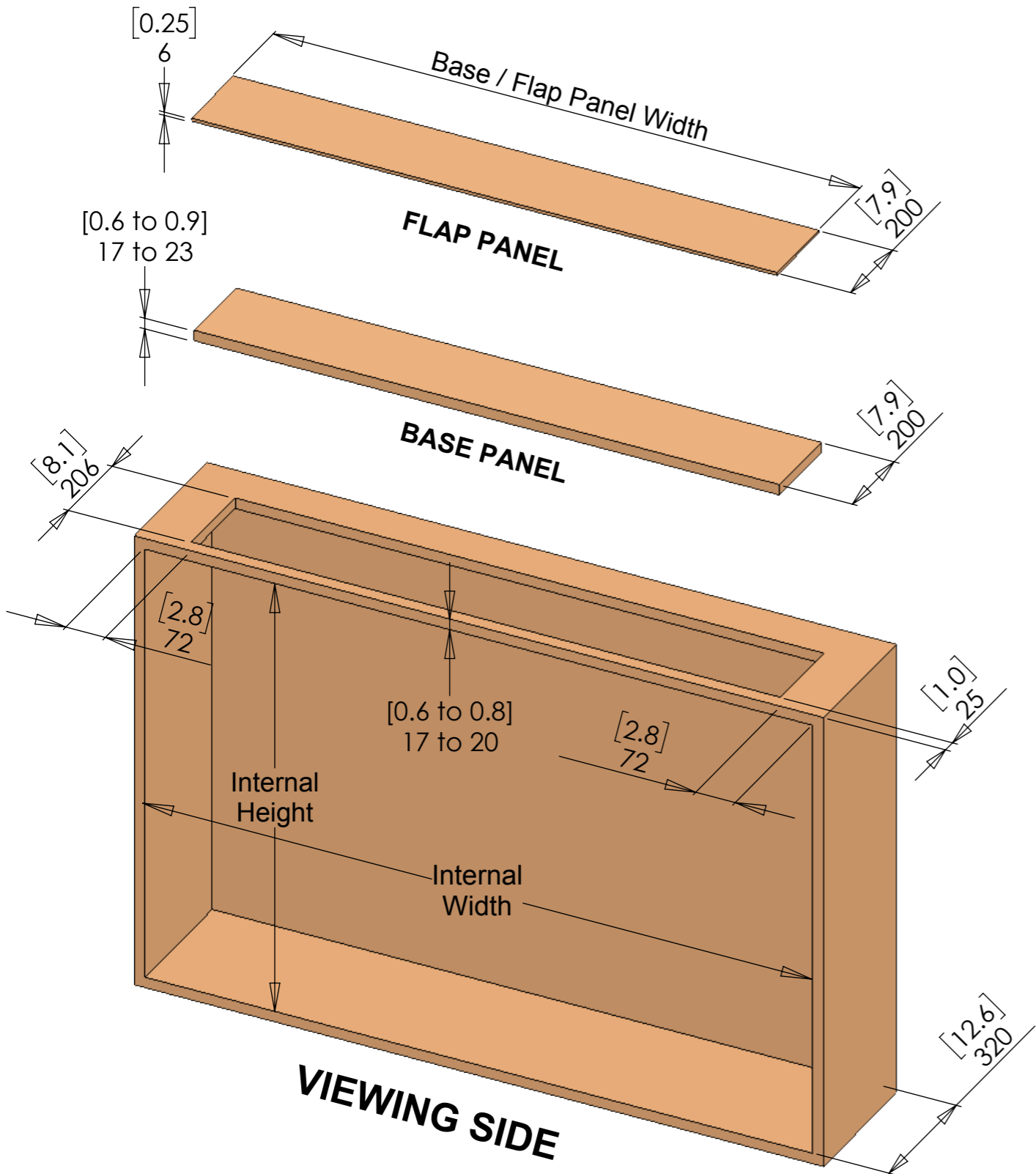

MAXIMUM SCREEN HEIGHT mm [inches]	MAXIMUM SCREEN HEIGHT FOR SWIVEL mm [inches]	INTERNAL HEIGHT mm [inches]
530 [20.9]	520 [20.4]	<b>H 710 [28.0]</b>
580 [22.8]	570 [22.4]	<b>H 760 [29.9]</b>
630 [24.8]	620 [24.4]	<b>H 810 [31.9]</b>
680 [26.8]	670 [26.3]	<b>H 860 [33.9]</b>
730 [28.7]	720 [28.3]	<b>H 910 [35.8]</b>
780 [30.7]	770 [30.3]	<b>H 960 [37.8]</b>
830 [32.7]	820 [32.2]	<b>H 1010 [39.8]</b>
880 [34.6]	870 [34.2]	<b>H 1060 [41.7]</b>

MAXIMUM SCREEN WIDTH mm [inches]	BASE / FLAP PANEL WIDTH mm [inches]	INTERNAL WIDTH mm [inches]
650 [25.6]	670 [26.4]	<b>W 820 [32.3] **</b>
750 [29.5]	770 [30.3]	<b>W 920 [36.3]</b>
850 [33.5]	870 [34.3]	<b>W 1020 [40.2]</b>
950 [37.4]	970 [38.2]	<b>W 1120 [44.1]</b>
1050 [41.3]	1070 [42.1]	<b>W 1220 [48.1]</b>
1150 [45.3]	1170 [46.1]	<b>W 1320 [52.0]</b>
1250 [49.2]	1270 [50.0]	<b>W 1420 [56.0]</b>
1350 [53.1]	1370 [53.9]	<b>W 1520 [59.9]</b>
1450 [57.1]	1470 [57.9]	<b>W 1620 [63.8]</b>
1550 [61.0]	1570 [61.8]	<b>W 1720 [67.7]</b>
1650 [65.0]	1670 [65.7]	<b>W 1820 [71.7]</b>

**IMPORTANT**  
When opting for a swivelling mechanism (PLS), maximum screen thickness is then reduced to 130mm [5.1"].

\*\* Swivel option NOT available with this width.



## PLS - Lift with Swivel Function

The PLS mechanism allows a screen to be rotated up to 180° clockwise and counter clockwise about its centre.

Up to four user defined angular positions can be stored in the mechanisms memory via the IR remote control.

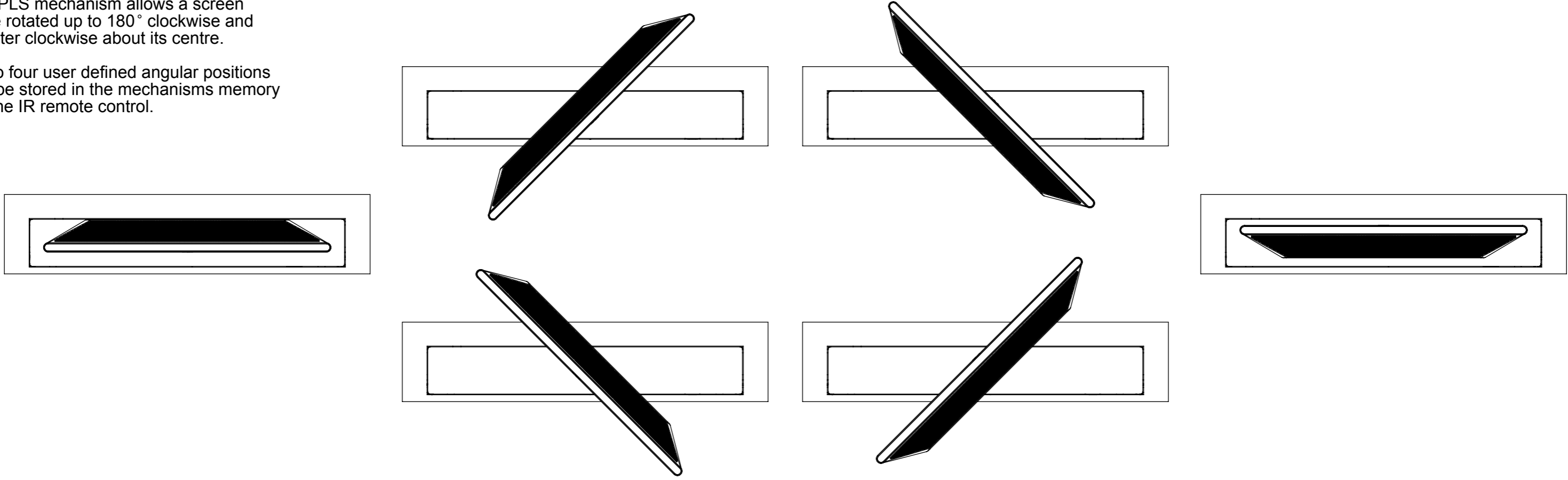

## PLS - Base Panel Details

The PLS mechanism requires the same base panel dimensions as a PL mechanism. The base panel used on a PLS mechanism simply requires an additional circular cut out for the swivelling mount the fix through.

Dimensions shown, right, are correct for Deep (D275) and Super Deep (D320) PLS mechanisms.

