

# KD-AMP220

2Ch 20 WPC @ 8 Ohm, 40 WPC @ 4 Ohm,  
Compact Digital Audio Amplifier

## Operating Instructions

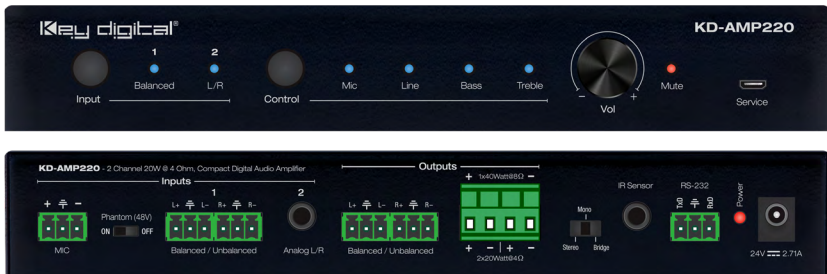

**Key digital**<sup>®</sup>

The Experts in Digital Video Technology and Solutions™

# Table of Contents

---

Introduction . . . . . 1

Quick Setup Guide . . . . . 2

Application Examples . . . . . 3

Connections, Buttons and LEDs . . . . . 4

Speaker Wiring . . . . . 7

IR Remote Control . . . . . 8

RS-232 Control . . . . . 8

Specifications . . . . . 12

Important Product Warnings & Safety Instructions: . . . . . 14

FCC Statement . . . . . 14

How to Contact Key Digital® . . . . . 15

Warranty Information . . . . . 15

**Always follow the instructions provided in this Operating Manual.**

## Introduction

---

The KD-AMP220 is a 2x20 watt Class-D amplifier with 8  $\Omega$  speaker output ideal for installation in presentation spaces. Input connections accommodate microphone, line level balanced/unbalanced, and line level 3.5mm stereo analog audio inputs. The output is a mix of audio from the microphone input and the selected audio input. Microphone and output volume levels may be variably controlled via IR, RS-232, or the front panel, and speaker level output may be set to bridge, stereo, or mono mode.

### Key Features

- › **Class D Amplification:** 2Ch 20 WPC @ 8 Ohm, 40 WPC @ 4 Ohm, bridged
- › **Mixing:** Output is a mix of microphone and the selected audio input
- › **Signal Processing:**
  - » Variable volume level set for each input
  - » Variable volume, bass, and treble for output
- › **Inputs:** Microphone (3-pin balanced, condenser/dynamic), 6-pin balanced stereo, 3.5mm stereo
- › **Phantom Power:** 48V phantom power for integration with condenser microphones
- › **Outputs:** Pre-amp line level (6-pin balanced), speaker level
- › **Speaker Level Output:** Bridge, stereo, or mono modes selectable
- › **Noise gate:** For consistent audio levels, prevention of ambient noise
- › **Control:** Front panel, RS-232, IR with external IR Sensor (included)
- › **Compact Size:** 4.84"(W) x 3.42"(D) x 1.3"(H)

### Accessories

- › Operating Instructions & Warranty card
- › 2 x L-type mounting ears
- › IR Remote Control
- › 2 x 3-pin, 1 x 4-pin, 2 x 6-pin Phoenix Connectors
- › Power Supply: 24V/2.71A (65W), screw-in type
- › IR Sensor

## Quick Setup Guide

---

1. Begin with the KD-AMP220 unit and all input/output devices turned off and power cables removed.
2. Connect audio output of source devices to the desired input of KD-AMP220 using high-quality audio cables.
3. Connect a microphone to the microphone input connector.
4. Set 48V phantom power mode switch as needed:
  - » a) ON for Condenser microphones
  - » b) OFF for Dynamic microphones
5. Adjust the speaker output mode selector based on the desired output mode of the KD-AMP220.
  - » a) STEREO – Stereo audio signals will maintain stereo audio on the outputs; 20 watts per output.
  - » b) MONO – Stereo audio signals will be summed to dual mono signals on the outputs; 20 watts per output.
  - » c) BRIDGE – Stereo audio signals will be summed to a single, high output audio output; 40 watts total output.
6. Connect speakers in accordance with above desired output mode. Use high quality speaker wire. See Speaker Wiring section for more information
7. For IR control, plug the IR receiver into the IR Sensor port. IR receiver should be mounted in line-of-sight location.
8. For RS-232 control, connect the master controller / control processor / control PC to the RS-232 port.
9. Connect power to the KD-AMP220.
10. Connect power to input and output devices. Power on attached audio devices.

# Application Examples

## Basic



## Advanced

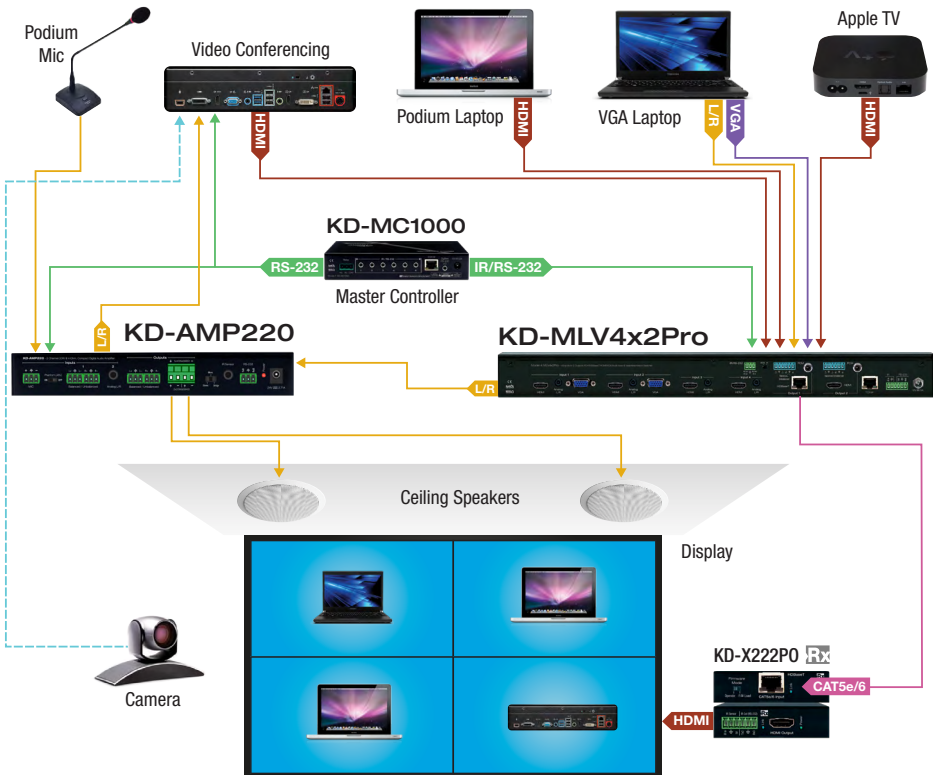

# Connections, Buttons and LEDs

## Rear Panel

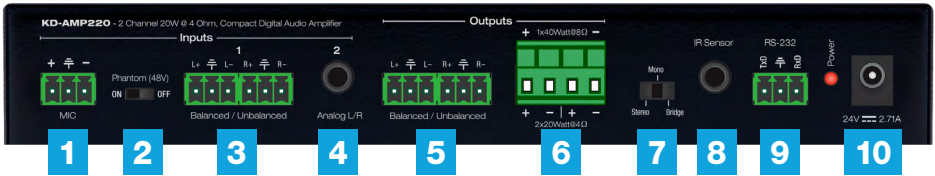

### Input Connections and Selector

- › **1. Microphone Input and 48V Phantom Power Mode Switch**
  - › a. Pin 1: +
  - › b. Pin 2: Ground
  - › c. Pin 3: -
- › **2. Phantom (48V) slide switch**
  - › a. ON: Condenser microphones
  - › b. OFF: Dynamic microphones
- › **3. Balanced/Unbalanced Analog Input 1**
  - › a. Pin 1: Left +
  - › b. Pin 2: Left Ground
  - › c. Pin 3: Left -
  - › d. Pin 4: Right +
  - › e. Pin 5: Right Ground
  - › f. Pin 6: Right -
- › **4. L/R Analog 3.5mm stereo Input 2**
  - › a. Tip: Left
  - › b. Ring: Right
  - › c. Sleeve: Ground

### Output Connections and Selector

- › **5. Balanced/Unbalanced Analog Audio Output**
  - › a. Pin 1: Left +
  - › b. Pin 2: Left Ground
  - › c. Pin 3: Left -
  - › d. Pin 4: Right +
  - › e. Pin 5: Right Ground
  - › f. Pin 6: Right -

## > 6. Speaker Output

Speaker Mode	Pin 1	Pin 2	Pin 3	Pin 4
STEREO	Left Channel+	Left Channel-	Right Channel+	Right Channel-
MONO	Mono+	Mono-	Mono+	Mono-
BRIDGE	Mono+	N/C	N/C	Mono-

## > 7. Speaker Output Mode Selector

- » a. STEREO: 2 channels 20W@4ohm speakers
- » b. MONO: 2 x mono 20W@4ohm speakers (stereo to mono conversion)
- » c. BRIDGE: Single 40W@8ohm speaker (stereo to mono conversion)

## Unit Control & Power

### > 8. IR Sensor Input

- » a. Tip: IR Sensor (5V) Power
- » b. Ring: IR Signal
- » c. Sleeve: Ground

### > 9. RS-232

- » a. Pin 1: TxD
- » b. Pin 2: Ground
- » c. Pin 3: RxD

### > 10. 24V DC Power Input

## Front Panel



## Input Connections and Selector

### > 1. Input Source select button and LEDs

### > 2. Control Button and LEDs

- » a. Used to select Volume or EQ control of Mic or Line inputs
  - » i. Mic for volume control of MIC input
  - » ii. Line for volume control of LINE (inputs 1 or 2)
  - » iii. Bass for bass level control of LINE (inputs 1 or 2)
  - » iv. Treble for treble level control of LINE (inputs 1 or 2)

### › 3. Volume Control Knob

- › a. Controls level of Mic, Line, Bass, and Treble
  - › i. Bass and Treble settings apply only to Line level input
- › b. Push to mute/un-mute respective control selection
  - › i. Mutes/un-mutes Mic input, if Mic is selected
  - › ii. Mutes/un-mutes Line input, if Line is selected
  - › iii. Mutes/un-mutes both Mic and Line inputs, if Bass or Treble are selected
- › Note: Volume adjustments do not affect muting status. If volume is adjusted to a muted source, it will remain muted.

### › 4. MUTE LED

- › a. Illuminated if selected control position is muted/un-muted

### › 5. USB Service port

- › a. Firmware update should only be applied if advised by Key Digital's Technical Support team.

- › **Factory Default via front panel:** To factory default unit, press & hold Input + Control buttons simultaneously for 10 seconds

# Speaker Wiring

## L/R Stereo

4Ω Load with 4Ω Speakers:

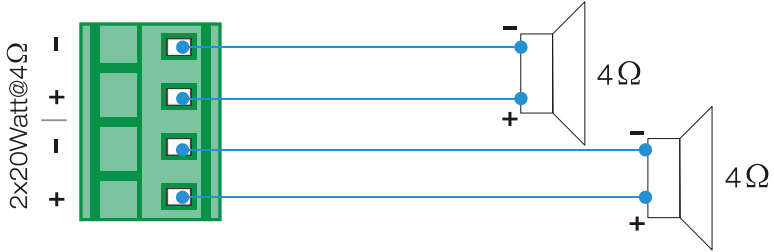

## L/R Stereo with Parallel Speakers

4Ω Load with 10W 8Ω Speakers:

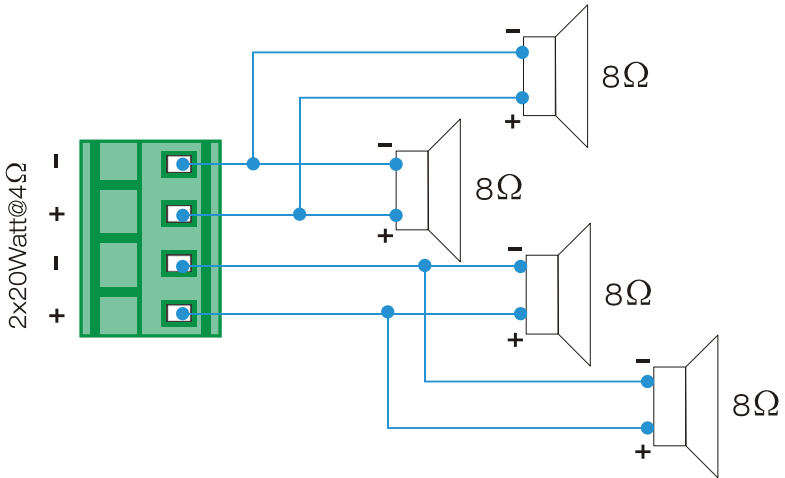

## Bridged Audio Option

8Ω Load with 8Ω Speakers:

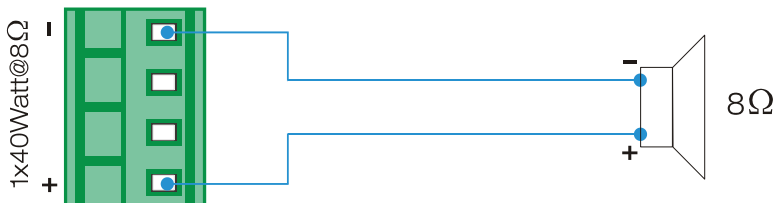

## IR Remote Control

IR Control must be achieved via included IR sensor only.  
There is no built-in IR sensor

- › **INPUT SEL:** Direct selection of input 1 or input 2
- › **MUTE:** Direct muting of MIC or LINE inputs. The SPEAKER button unmutes all sources
- › **VOLUME CONTROL:** Direct volume and level controls for Mic, Line, Bass, and Treble.
- › **Note:** IR Control must be achieved via included IR sensor only. There is no built-in IR sensor.



## RS-232 Control

KD-AMP220 gives access to all software functions when used controlled by RS-232

- › Baud Rate = 9600 bits per second
- › Data Bits = 8
- › Stop Bits = 1
- › Parity = None
- › Flow Control = None
- › Carriage Return: Required
- › Commands are not case-sensitive.  
Spaces shown below may be excluded.
- › Carriage return is required at the end of each string.

### RS-232 cable pinout

Master Controller	KD-AMP220
Tx	Rx
Rx	Tx
Ground	Ground

### Input Switching

Description	Command	Command Example and Response
Switch to Audio Input1	<b>SPO01SA01</b>	SPO01SA01 Output Audio switch to Input 01
Switch to Audio Input2	<b>SPO01SA02</b>	SPO01SA02 Output Audio switch to Input 02
Switch to Audio Input1 *Redundant Command	<b>SPO01SI01</b>	SPO01SA01 Output Audio switch to Input 01
Switch to Audio Input2 *Redundant Command	<b>SPO01SI02</b>	SPO01SA02 Output Audio switch to Input 02

## Volume and EQ Settings

Description	Command	Command Example and Response
Turn Up the Volume of MIC Audio	<b>SPI01AVU</b>	SPI01AVU Volume of MIC Audio [51] turn Up Note: [xx] = Level 00 - 60
Turn Down the Volume of MIC Audio	<b>SPI01AVD</b>	SPI01AVD Volume of MIC Audio [51] turn Down Note: [xx] = Level 00 - 60
Turn Up the Volume of Line Audio	<b>SPO01AVU</b>	SPO01AVU Volume of Line Audio [51] turn Up Note: [xx] = Level 00 - 60
Turn Down the Volume of Line Audio	<b>SPO01AVD</b>	SPO01AVD Volume of Line Audio [51] turn Down Note: [xx] = Level 00 - 60
Turn Up the Bass Level of Line Audio	<b>SPO01ALU</b>	SPO01ALU Bass Level of Line Audio [04] turn Up Note: [xx] = Level 00 - 08
Turn Down the Bass Level of Line Audio	<b>SPO01ALD</b>	SPO01ALD Bass Level of Line Audio [04] turn Down Note: [xx] = Level 00 - 08
Turn Up the Treble Level of Line Audio	<b>SPO01AHU</b>	SPO01AHU Treble Level of Line Audio [04] turn Up Note: [xx] = Level 00 - 08
Turn Down the Treble Level of Line Audio"	<b>SPO01AHD</b>	SPO01AHD Treble Level of Line Audio [04] turn Down Note: [xx] = Level 00 - 08
Set the Volume of MIC Audio to xx[ xx = 00~60 ]	<b>SPI01AVxx</b>	SPO01AV51 Volume of MIC Audio set to 51 Note: [xx] = Level 00 - 60
Set the Volume of Line Audio to xx[ xx = 00~60 ]	<b>SPO01AVxx</b>	SPO01AV51 Volume of Line Audio set to 51 Note: [xx] = Level 00 - 60
Set the Bass Level of Line Audio to xx[ xx = 00~08 ]	<b>SPO01ALxx</b>	SPO01AL04 Bass Level of Line Audio set to 04 Note: [xx] = Level 00 - 08
Set the Treble Level of Line Audio to xx[ xx = 00~08 ]	<b>SPO01AHxx</b>	SPO01AH04 Volume of Line Audio set to 04 Note: [xx] = Level 00 - 08

## Muting

Description	Command	Command Example and Response
Mute both MIC and LINE Audio	<b>SPO01AE</b>	SPO01AE Output Audio Mute Enabled
Unmute both MIC and Line Audio	<b>SPO01AD</b>	SPO01AD Output Audio Mute Disabled
Mute MIC Audio Only	<b>SPI01AE</b>	SPI01AE MIC Audio Mute Enabled
Mute Line Audio Only	<b>SPI02AE</b>	SPI02AE Line Audio Mute Enabled
Unmute MIC Audio Only	<b>SPI01AD</b>	SPI01AD MIC Audio Mute Disabled
Unmute Line Audio Only	<b>SPI02AD</b>	SPI02AD Line Audio Mute Disabled
Set Noise Gate ON	<b>SPO01NGON</b>	SPO01NGON Noise Gate is ON
Set Noise Gate OFF	<b>SPO01NGOFF</b>	SPO01NGOFF Noise Gate is OFF

## System Query

Description	Command	Response
Print Help Message	<b>H</b>	See below
Print Status Message	<b>STA</b>	See below

## Factory Reset

Description	Command	Command Example and Response
Set Factory Default	<b>SPCDF</b>	SPCDF Factory Default is Done Note: Default settings <ul style="list-style-type: none"> <li>» Line Source: Input 1</li> <li>» Mic Volume: 45</li> <li>» Mic Mute: OFF</li> <li>» Line Volume: 45</li> <li>» Line Mute: OFF</li> <li>» Bass: 4</li> <li>» Treble: 4</li> <li>» Noise Gate: ON</li> </ul>

## The Help command “H” returns a full list of all possible RS-232 commands:

**KD-AMP220>H**

```

-----
--          Key Digital Systems  HELP          --
-----
--          KD-AMP220          F/W Version : V1.0.0  --
-- SPO01SA01 : Switch to Audio Input1             --
-- SPO01SA02 : Switch to Audio Input2             --
-- SPI01AE   : Mute MIC Audio Input               --
-- SPI01AD   : Unmute MIC Audio Input             --
-- SPI02AE   : Mute LINE Audio Input              --
-- SPI02AD   : Unmute LINE Audio Input           --
-- SPO01AE   : Mute Audio Output                  --
-- SPO01AD   : Unmute Audio Output                --
-- SPO01NGON : Set Noise Gate ON                  --
-- SPO01NGOFF: Set Noise Gate OFF                 --
--
-- SPI01AVU : Turn Up the Volume of MIC           --
-- SPI01AVD : Turn Down the Volume of MIC         --
-- SPO01AVU : Turn Up the Volume of LINE          --
-- SPO01AVD : Turn Down the Volum of LINE        --
-- SPO01ALU : Turn Up the Bass Level of LINE     --
-- SPO01ALD : Turn Down the Bass Level of LINE   --
-- SPO01AHU : Turn Up the Treble Level of LINE    --
-- SPO01AHD : Turn Down the Treble Level of LINE --
-- xx = [00~60], yy = [00~08]                   --
-- SPI01AVxx : Set the Volume of MIC to xx       --
-- SPO01AVxx : Set the Volume of LINE to xx      --
-- SPO01ALyy : Set the Bass Level of LINE to yy  --
-- SPO01AHyy : Set the Treble Level of LINE to yy--
--
--
-- SPCDF      : Set Factory Default               --
-- H          : Show Help                         --
-- STA       : Show Status                       --
-----

```

## The Status command “STA” returns unit status for all settings

**KD-AMP220>sta**

```

-----
--          Key Digital Systems  STATUS          --
-----
--          KD-AMP220          F/W Version : V1.0.0  --
-- Line Audio Source : Input 1                     --
-- MIC Audio       : Volume = 45, Mute = OFF        --
-- Line Audio      : Volume = 45, Mute = OFF        --
--                 Bass = 4, Treble = 4            --
-- Noise Gate     : ON                             --
-----

```

## Specifications

### I/O Connections

Analog Inputs	One (1) 6-pin Phoenix Connector; One (1) 3.5mm TRS Connector
Microphone Input	One (1) 3-pin Phoenix Connector
Control (Front Panel)	Push Button, Rotary Knob
Control (Rear Panel)	RS-232 via One (1) 3-pin Phoenix Connector; IR via One (1) 3.5mm TRS Connector
Microphone 48V Phantom Power Mode Switch	One (1) 2-Position Slide Switch
Output Signal Format Selector	One (1) 3-Position Slide Switch
Balanced/Unbalanced Analog Audio Output	One (1) 6-pin Phoenix Connector
Speaker Output	One (1) 4-pin/5 mm Phoenix Connector
24V DC Power	One (1) Barrel (5.5 mm OD, 2.1 mm ID)

### Audio Performance

Input Impedance	>10k $\Omega$
Output Impedance	50 $\Omega$ Analog Output; 4/8 $\Omega$ Speaker Output
Maximum Rated Power Output	40 Watts
Frequency Response	120 Hz to 20 kHz
Common Mode Rejection Ratio (CMRR)	>70 dB at 20 Hz to 20 kHz
Signal to Noise Ratio (SNR)	80 dB (Max)
Total Harmonic Distortion + Noise (THD+N)	1% at 1 kHz; 0.3% at 20 kHz at Nominal Level
Voltage Gain	32 dB

## **Chassis and Environmental**

Enclosure	Painted Aluminum
Dimensions (W x H x D)	8.661" x 1.299" x 4.094" (LxDxH)
Net Weight	1.153 Lb
Operating Temperature	+32° to +104° F (0° to +40° C)
Operating Humidity	20% to 90%, Non-condensing
Storage Temperature	+14° to +140° F (-10° to +60° C)
Storage Humidity	20% to 90%, Non-condensing

## **Power, ESD, and Regulatory**

Minimum Power Consumption	5 watts
Maximum Power Consumption	45 watts
Power Supply Input Voltage	100-240v AC at 50/60 Hz at 0.5 A
Power Supply Output Rating	24V DC at 2.71 A
ESD Protection	15kV
Device Regulatory	CE, FCC
Power Supply Regulatory	CE, FCC



## Important Product Warnings:

---

1. Connect all cables before providing power to the unit.
2. Test for proper operation before securing unit behind walls or in hard to access spaces.
3. If installing the unit into wall or mounting bracket into sheet-rock, provide proper screw support with bolts or sheet-rock anchors.



## Safety Instructions:

---

**Please be sure to follow these instructions for safe operation of your unit.**

1. Read and follow all instructions.
2. Heed all warnings.
3. Do not use this device near water.
4. Clean only with dry cloth.
5. Install in accordance with the manufacturer's instructions.
6. Do not install near any heat sources such as radiators, heat registers, stoves, or other apparatus (including amplifiers) that produce heat.
7. Only use attachments/accessories specified by the manufacturer.
8. Refer all servicing to qualified service personnel. Servicing is required when the device has been damaged in any way including:
  - » Damage to the power supply or power plug
  - » Exposure to rain or moisture



## Power Supply Use:

---

**You MUST use the Power Supply provided with your unit or you VOID the Key Digital® Warranty and risk damage to your unit and associated equipment.**



## FCC Statement

---

This equipment generates, uses and can radiate radio frequency energy and, if not installed and used in accordance with the instructions, may cause harmful interference to radio communications. It has been tested and found to comply with the limits for a Class B digital device, pursuant to part 15 of the FCC Rules. These limits are designed to provide reasonable protection against harmful interference in a commercial installation.

Operation of this equipment in a residential area is likely to cause interference, in which case the user at their own expense will be required to take whatever measures may be necessary to correct the interference.

Any changes or modifications not expressly approved by the manufacture would void the user's authority to operate the equipment.



## How to Contact Key Digital®

---

### **System Design Group (SDG)**

For system design questions please contact us at:

- › Phone: 914-667-9700
- › E-mail: [sdg@keydigital.com](mailto:sdg@keydigital.com)

### **Customer Support**

For customer support questions please contact us at:

- › Phone: 914-667-9700
- › E-mail: [customersupport@keydigital.com](mailto:customersupport@keydigital.com)

### **Technical Support**

For technical questions about using Key Digital® products, please contact us at:

- › Phone: 914-667-9700
- › E-mail: [tech@keydigital.com](mailto:tech@keydigital.com)

### **Repairs and Warranty Service**

Should your product require warranty service or repair, please obtain a Key Digital® Return Material Authorization (RMA) number by contacting us at:

- › Phone: 914-667-9700
- › E-mail: [rma@keydigital.com](mailto:rma@keydigital.com)

### **Feedback**

Please email any comments/questions about the manual to:

- › E-mail: [customersupport@keydigital.com](mailto:customersupport@keydigital.com)

## Warranty Information

---

All Key Digital® products are built to high manufacturing standards and should provide years of trouble-free operation. They are backed by a Key Digital Limited 3 Year Product Warranty Policy. <http://www.keydigital.com/warranty.htm>





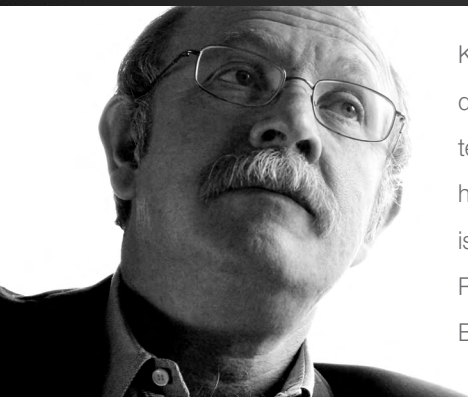

Key Digital®, led by digital video pioneer Mike Tsinberg, develops and manufactures high quality, cutting-edge technology solutions for virtually all applications where high-end video and control are important. Key Digital® is at the forefront of the video industry for Home Theater Retailers, Custom Installers, System Integrators, Broadcasters, Manufacturers, and Consumers.

Key Digital® Systems :: 521 East 3rd Street :: Mount Vernon, NY 10553  
Phone : 914.667.9700 Fax : 914.668.8666 Web : [www.keydigital.com](http://www.keydigital.com)