

TSLM-MO-2

MARINE OUTDOOR TELESCOPIC SCREEN LIFT

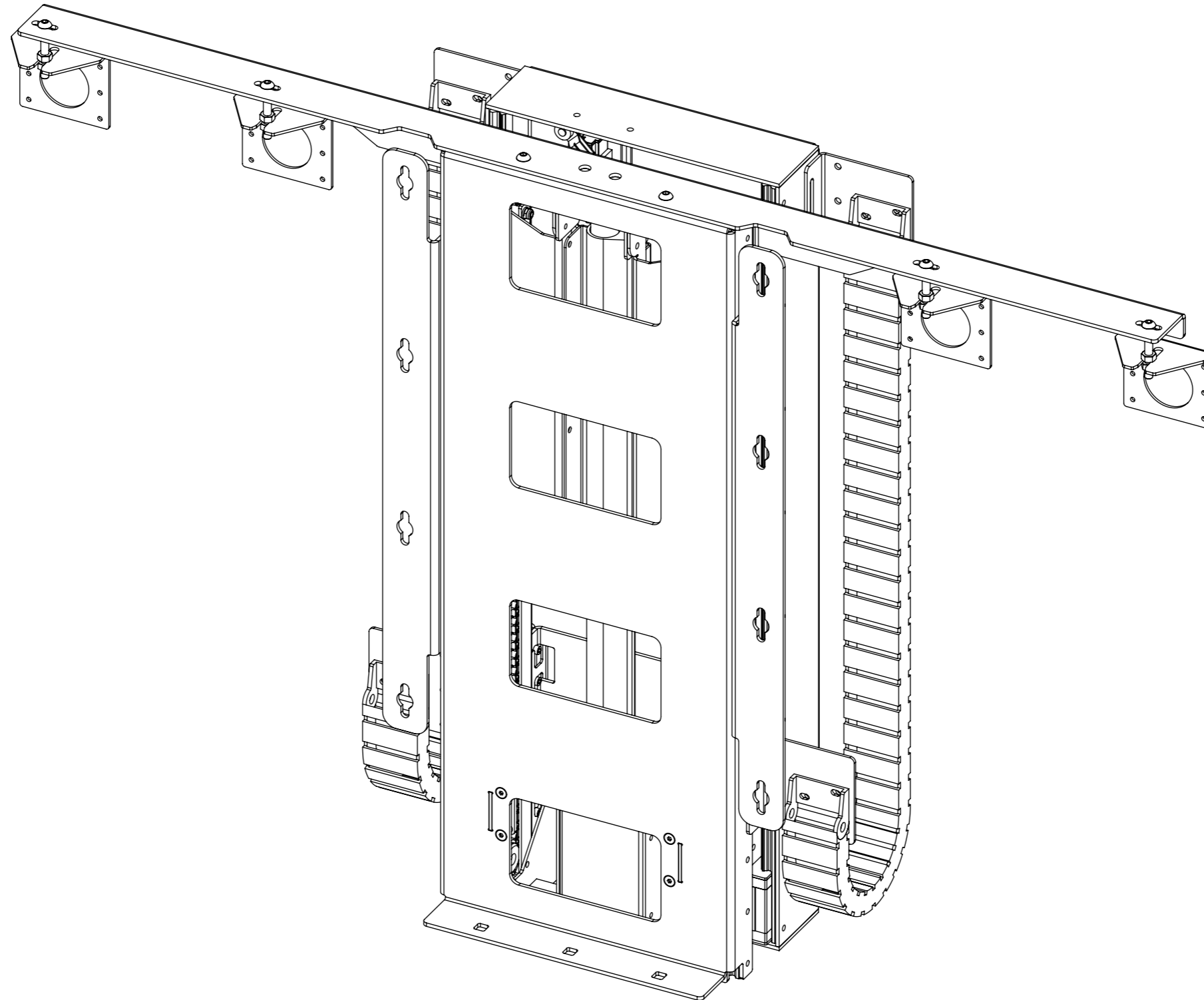

future automation



TSLM-MO-2

MARINE OUTDOOR TELESCOPIC SCREEN LIFT



future automation

SPECIFICATION	MEASUREMENTS
Product Dimensions	742mm (29 3/16") x 1280mm (50 3/8") x 240mm (9 7/16")
Minimum Screen Height	695mm (27 3/8")
Maximum Screen Height	875mm (34 7/16")
Minimum Screen Width	1280mm (50 3/8") - (Lower Width option available upon request)
Maximum Weight Capacity (Screen + Enclosure)	75Kg (165lb)
Product Weight	40Kg (88lb)
Packaging Dimensions	TBC
Shipping Weight	TBC
Movement Type	Motorised
Power Supply Required	110V - 240V
Power Consumption Max.	250W
Power Consumption Standby	3W
Mounting Patterns Supported	VESA 200, 300, 400 W x 200, 300, 400 H - (Other VESA patterns upon request)
Control Options	IR Remote, RS232, Contact Closure
Product Options / Features	Specific B&O and Loewe mounts / adapters, Custom RAL paint finishes, Outdoor suitable version
Package Contents	Mechanism, IR remote control
Marine Suitable	YES
Outdoor Suitable	YES

TSLM-MO-2

MARINE OUTDOOR TELESCOPIC SCREEN LIFT



GENERAL INFORMATION

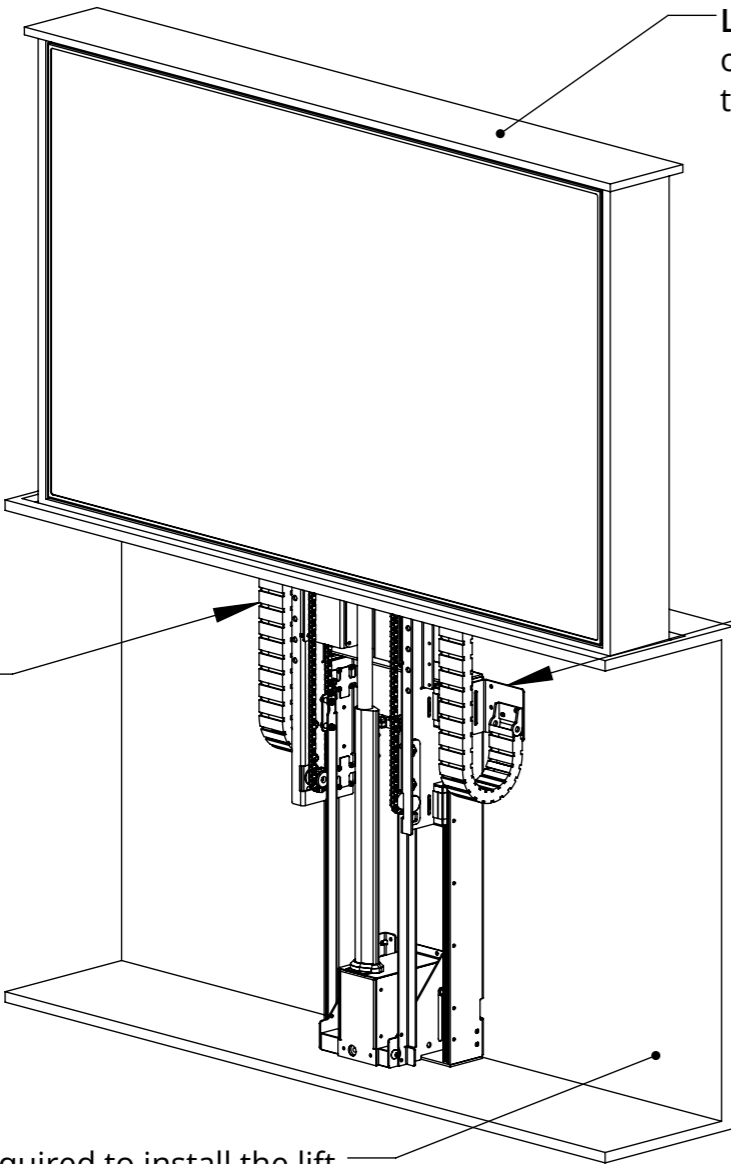

LID and ENCLOSURE - To be made by others. Total allowable weight for all timber work and the screen **75Kg**.

Screen cables enter here.

Screen cables enter here.

Front access is required to install the lift.
 Allow 20mm+ in front of the screen if the mechanism is to be partially sunk below floor level.

The lid must be easily removed if the mechanism was stuck in the down position. A lift off arrangement being ideal. The fixings for the screen are then accessible so it can then be lifted off to give access to the motor.

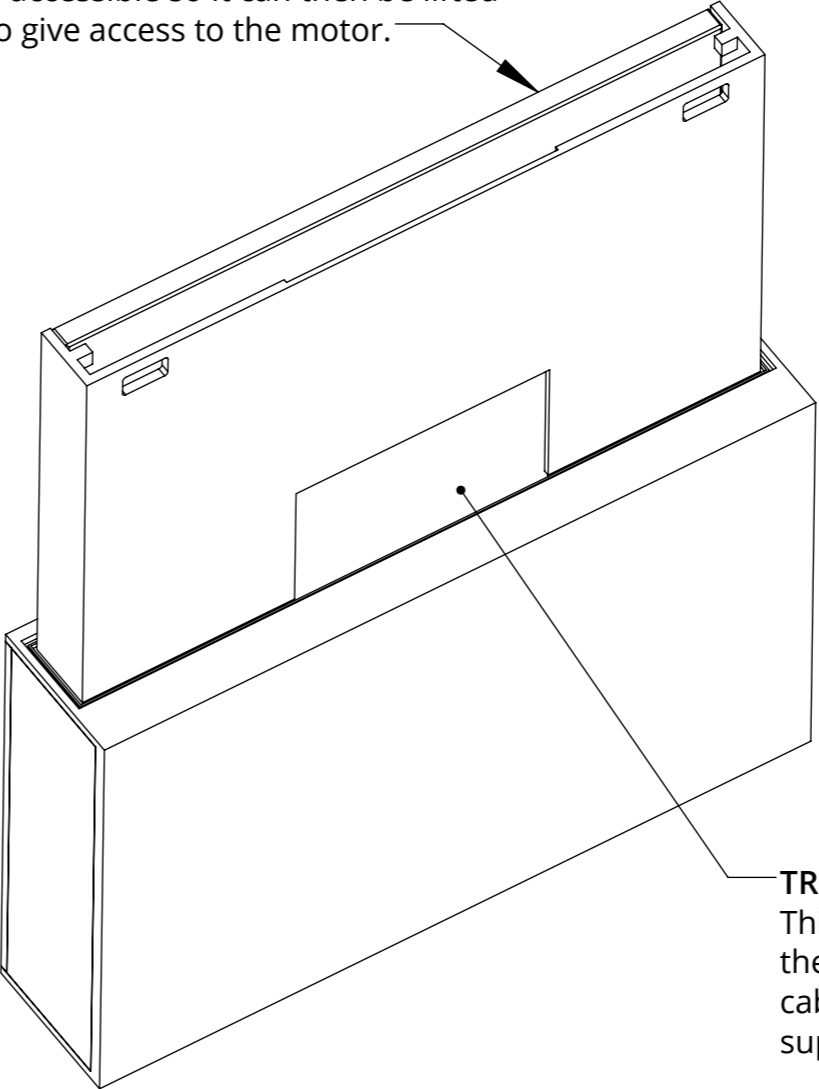

TRIM PANEL - Not supplied. This trim panel is lifted up as the screen is lowered into the cabinet. Brackets are supplied to attach it.

VESA 400 wide mounting pattern covered. Brackets have full height adjustment.

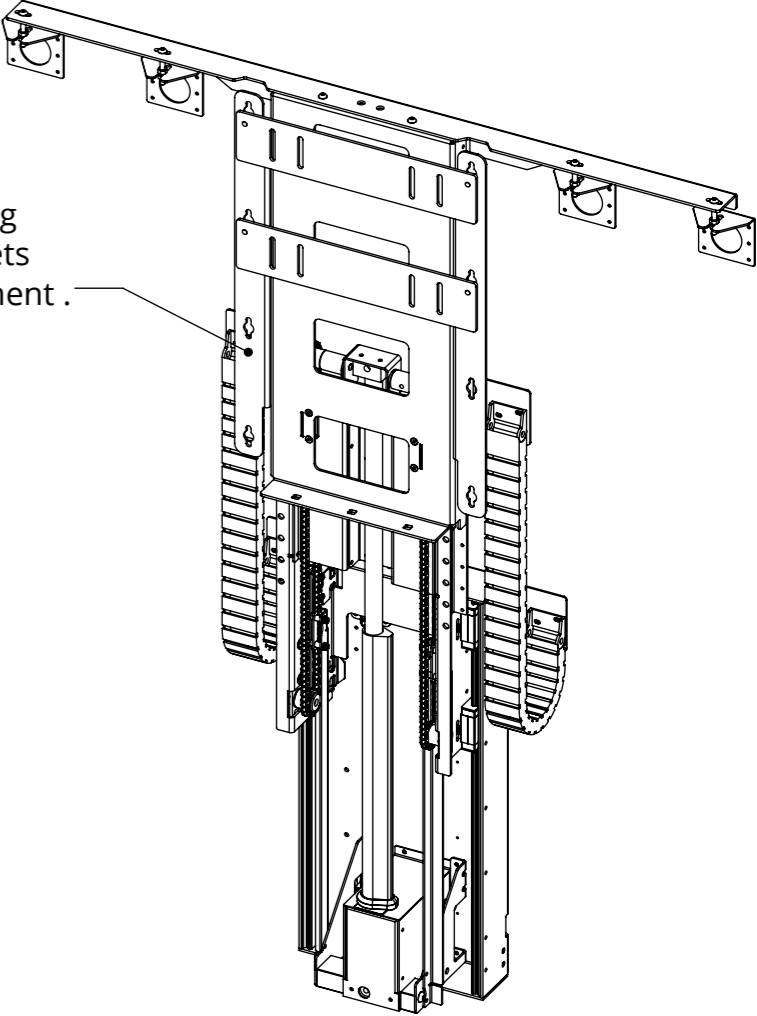

TSLM-MO-2

MARINE OUTDOOR TELESCOPIC SCREEN LIFT



future automation

CABINET SIZING

All sizing calculations are based off a 20mm [0.79"] box enclosure panel thickness. Any increases in this thickness will increase the required space.

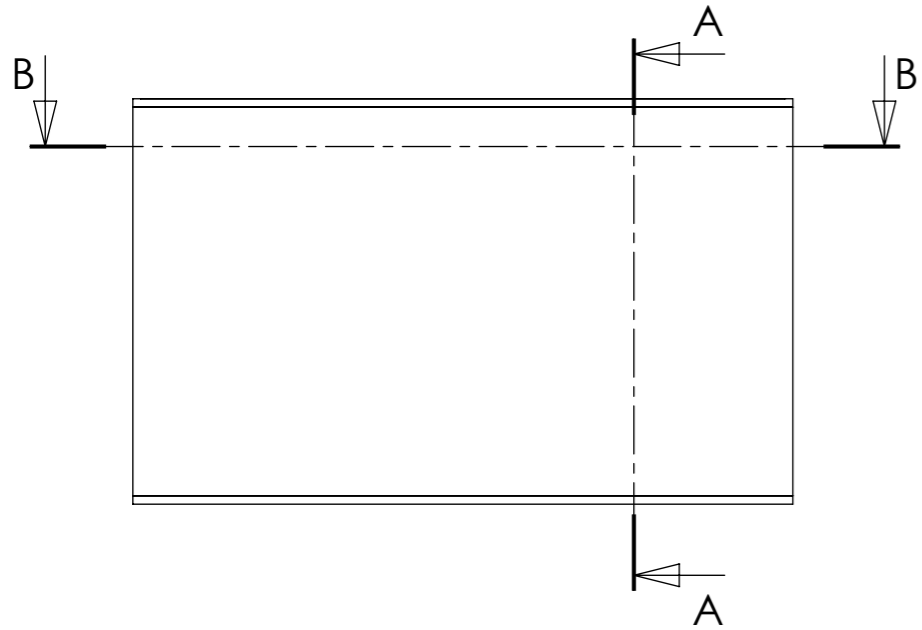

SECTION B-B
SCALE 1 : 7

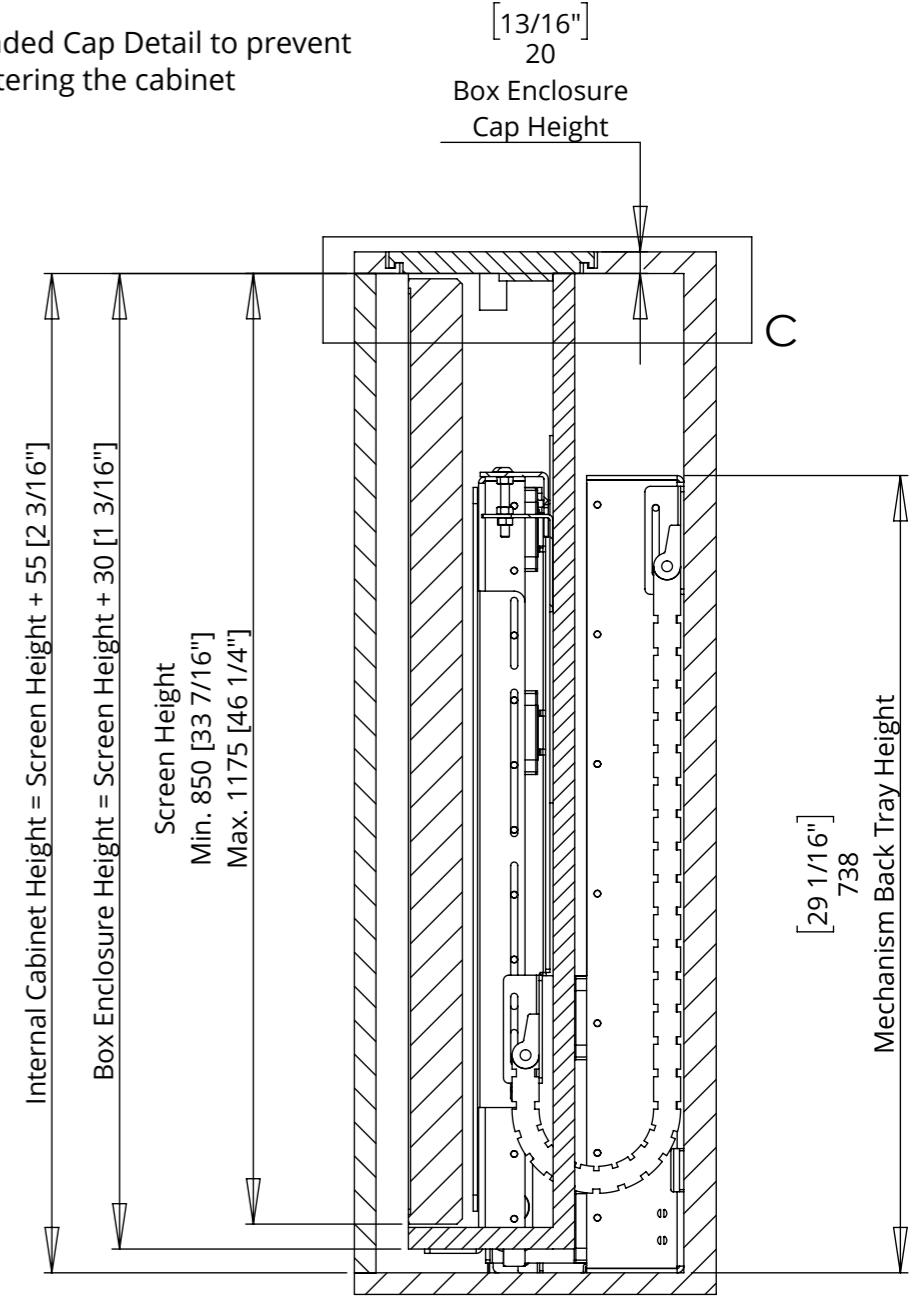
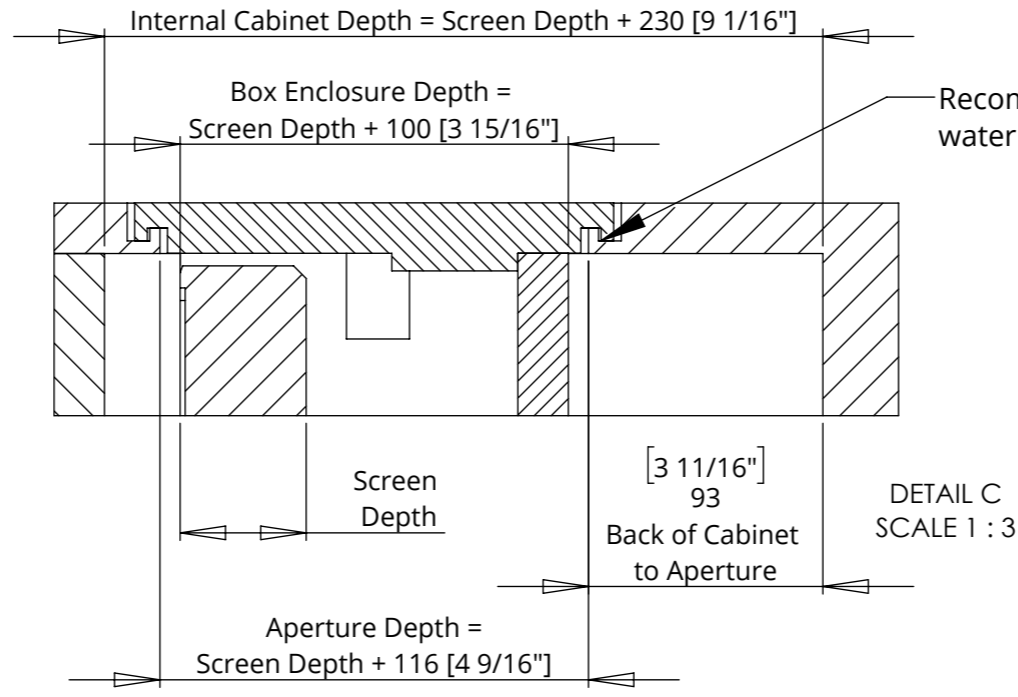
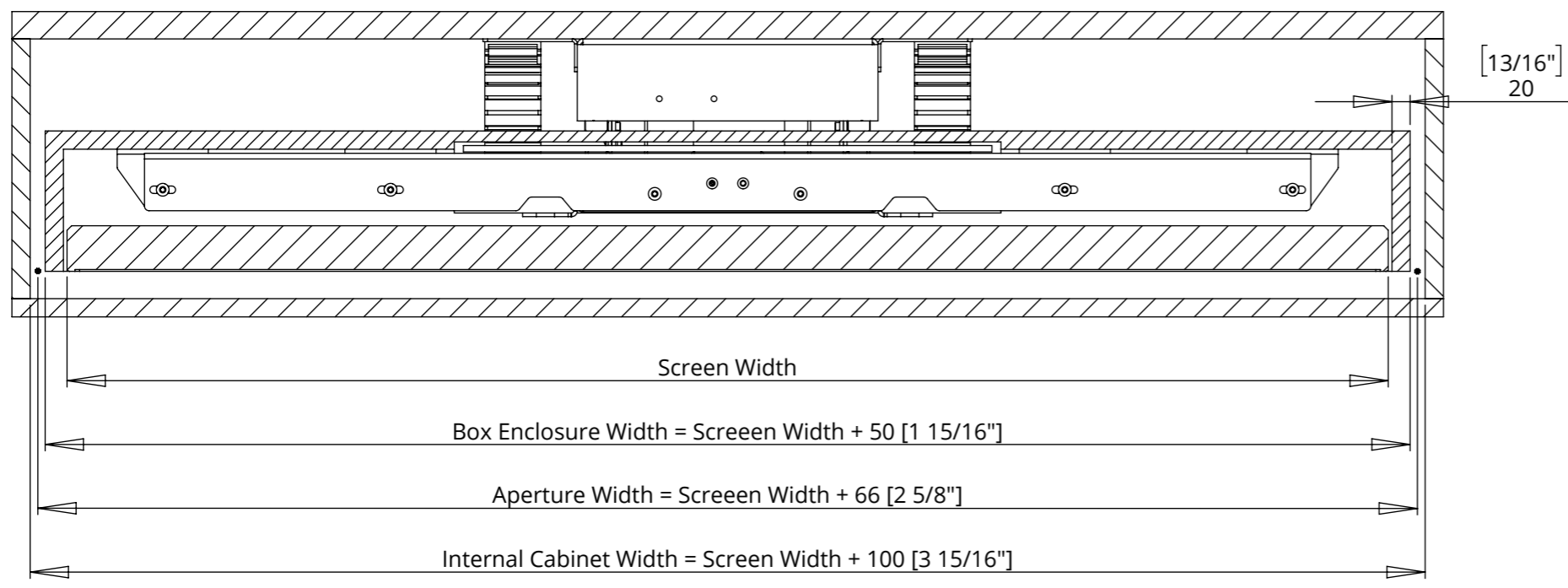

TECHNICAL SHEET

ISSUE 001
SHEET 4

TSLM-MO-2

MARINE OUTDOOR TELESCOPIC SCREEN LIFT

BOX ENCLOSURE DETAILING

The Screen, Enclosure, Lid and the Trim panel must weigh no more than 75Kg.

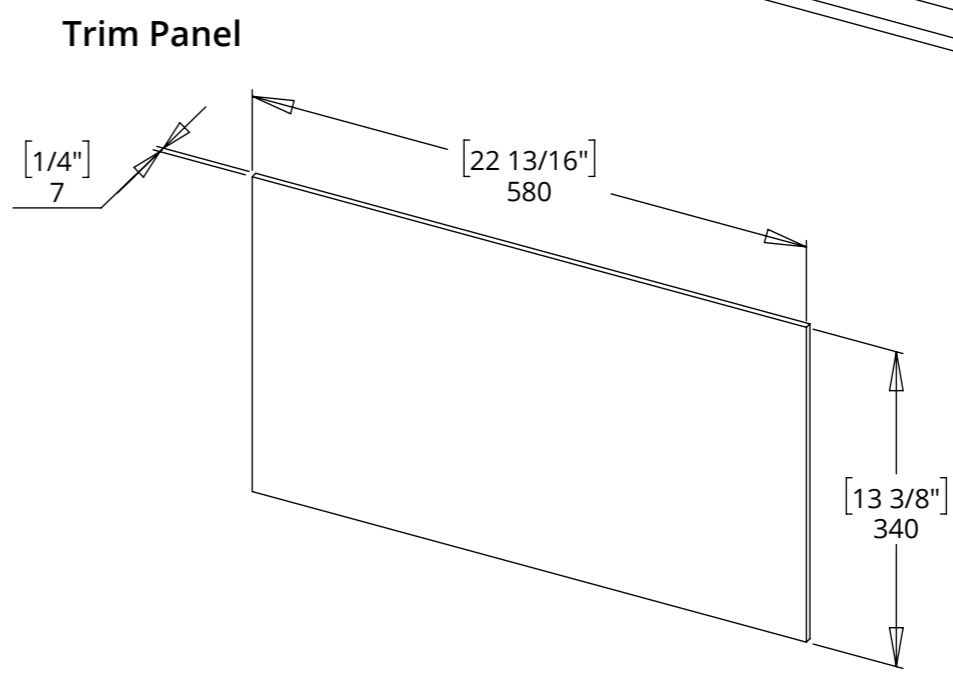
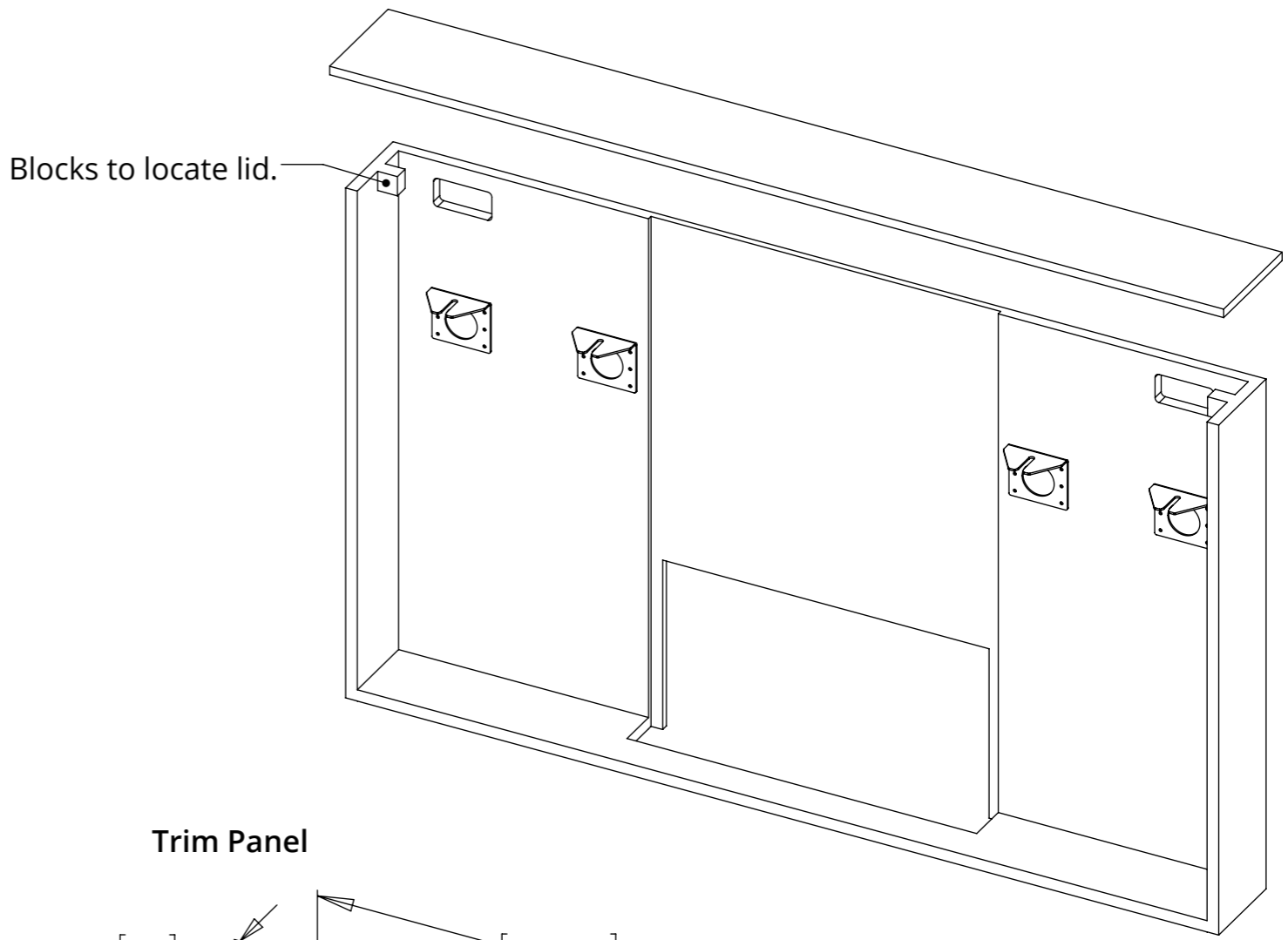
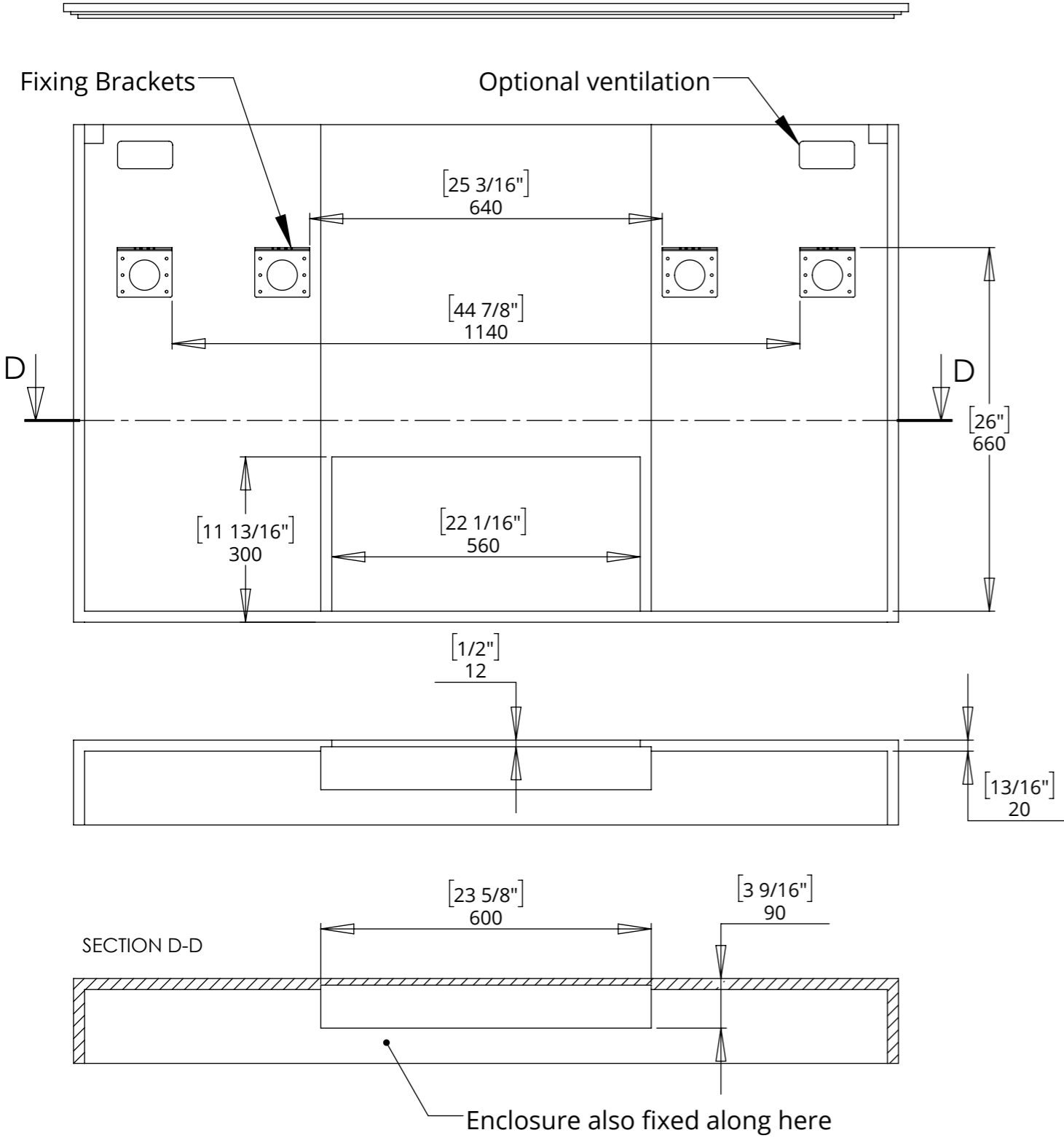

TSLM-MO-2

MARINE OUTDOOR TELESCOPIC SCREEN LIFT



future automation

INSTALL INSTRUCTIONS

- Check that the cabinet, enclosure, lid and the trim panel are made to the details shown on the previous pages.
- You can stand the mechanism up on its base to test it before putting in the cabinet. See control document for details. Use the IR remote with caution and always cover the STOP button in case of issues.
- Centrally fix the mechanism to the back of the cabinet in the places shown.
- Run up and down and then add the enclosure.
- Adjust the position of the enclosure and adjust the up and down switches with caution. Temporarily add lid to check height.
- Run screen cables up into enclosure. Secure cables as they enter and leave the cable tracks with cable ties. Make sure no cables can get tangled or caught as the mechanism moves.
- Add trim panel. And adjust. This trim panel moves up into position as the TV lifts. Observe this movement and understand it before fixing.
- The uprights can be adjusted in height. Use the fixings on each side through the slots. Put as many fixings back in when finished as these also secure the linear guides. Loosely put the bolts in the back of the screen and then hook it on to the mount plates on the mechanism.
- Check movement with screen with caution.

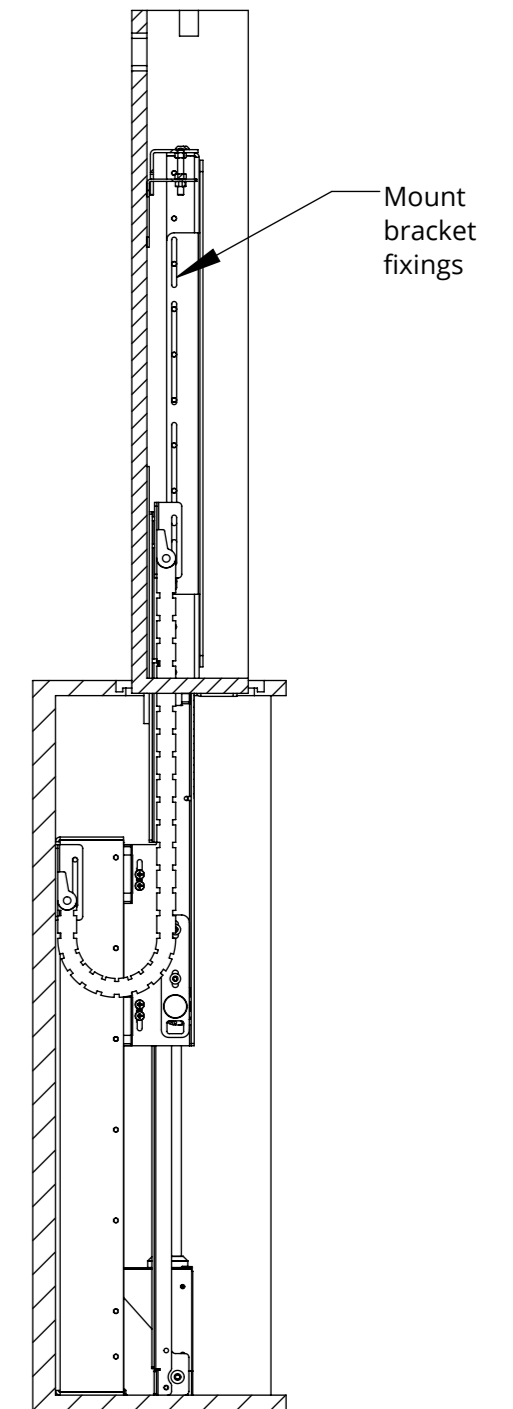
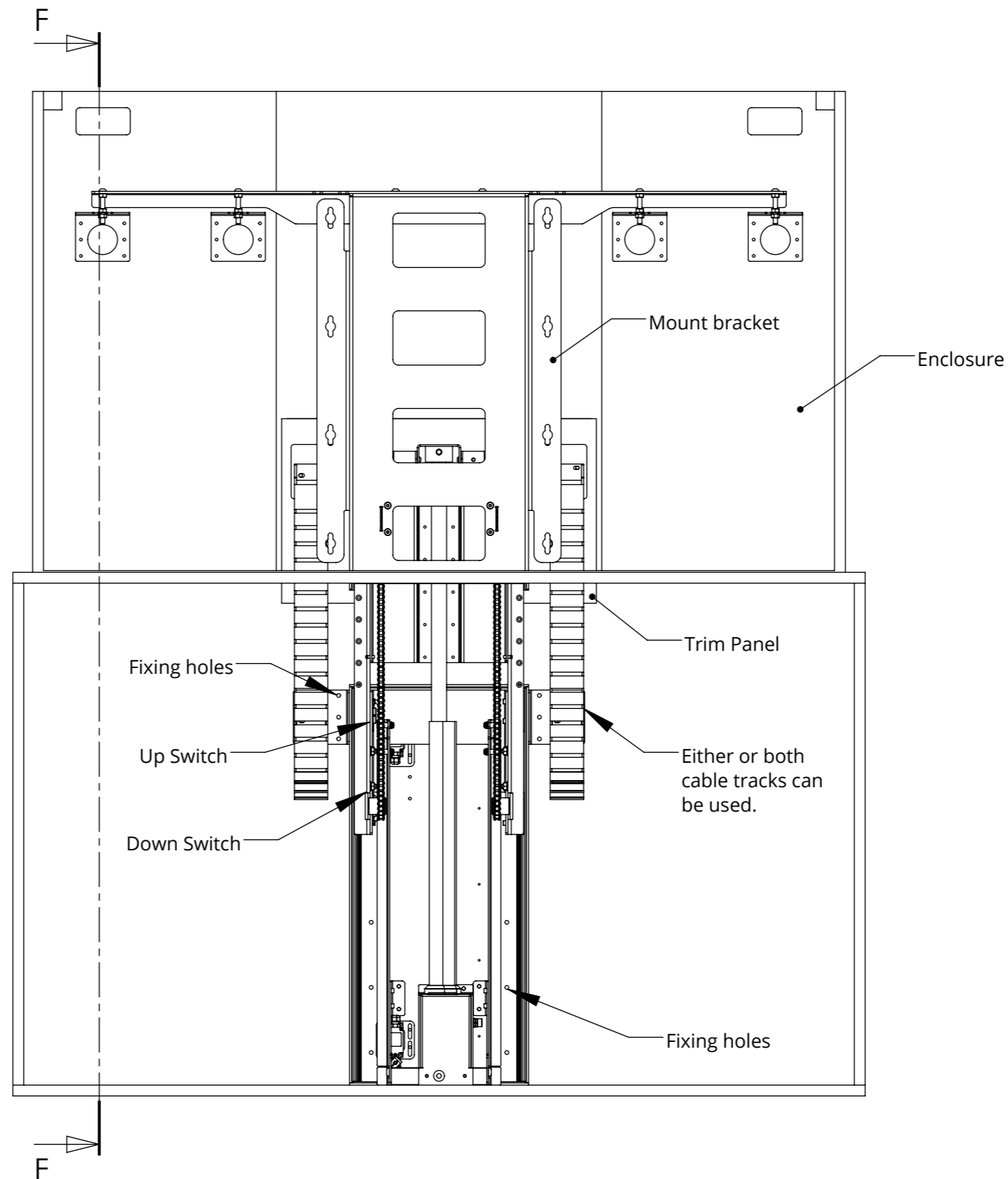

SECTION F-F