

WB16-2S

WALL BOX 16 FOR TWIN STUD WIDTH

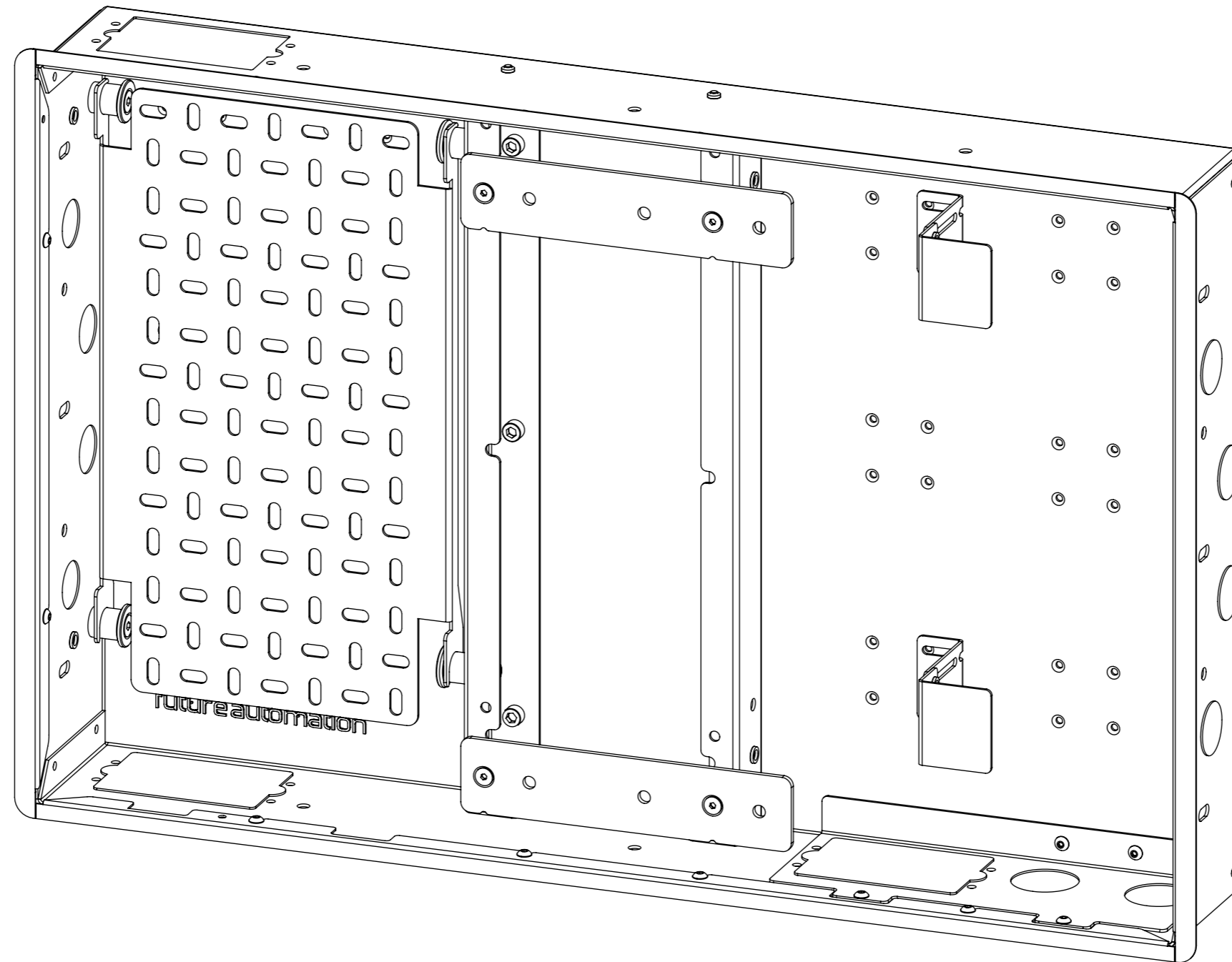

future automation



future automation

WB16-2S

WALL BOX 16 FOR TWIN STUD WIDTH



future automation

SPECIFICATION	MEASUREMENTS
Product Dimensions (in wall)	403mm [15 7/8"] x 624mm [24 9/16"] x 96.5mm [3 13/16"]
PS Bracket Compatilby	PS32
Packaging Dimensions	TBC
Shipping Weight	TBC
Product Options / Features	Custom RAL paint finishes, WB21-2S, WB26-2S, WB31-2S
Package Contents	Wall box with 'hook on' mount plate, 3 x Pairs of clamp brackets, 2 x PS bracket mount brackets, 4 x Horizontal trim strips, 2 x Vertical trim strips, 1 x WattBox mount bracket set
Marine Suitable	No

WB16-2S

WALL BOX 16 FOR TWIN STUD WIDTH

DIMENSIONS

Contents include:

- Wall box
- 3 x Pairs of clamp brackets
- 2 x Horizontal trim strips
- 2 x Vertical trim strips
- 1 x Accessory plate
- 1 x WattBox mount bracket set

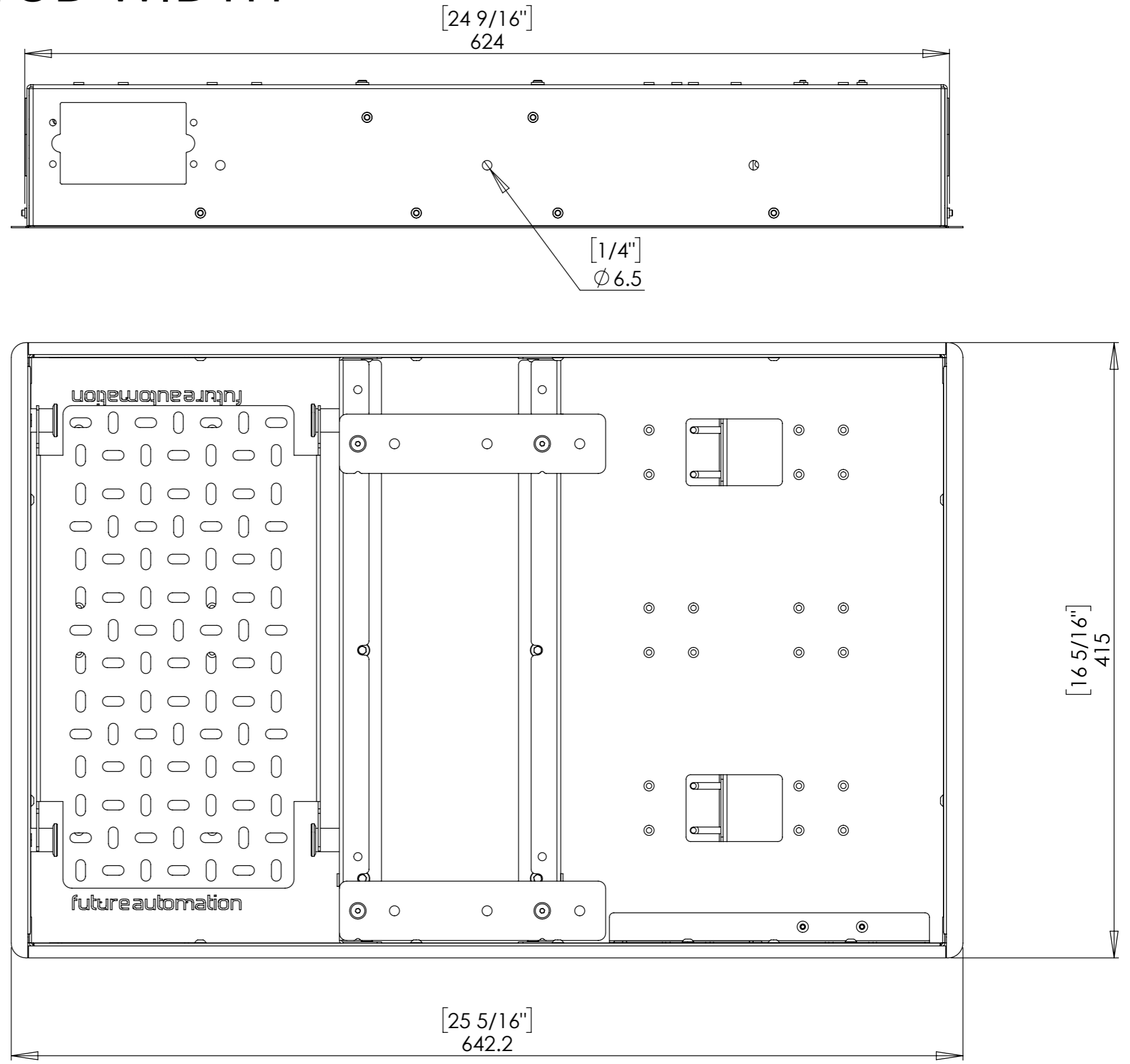
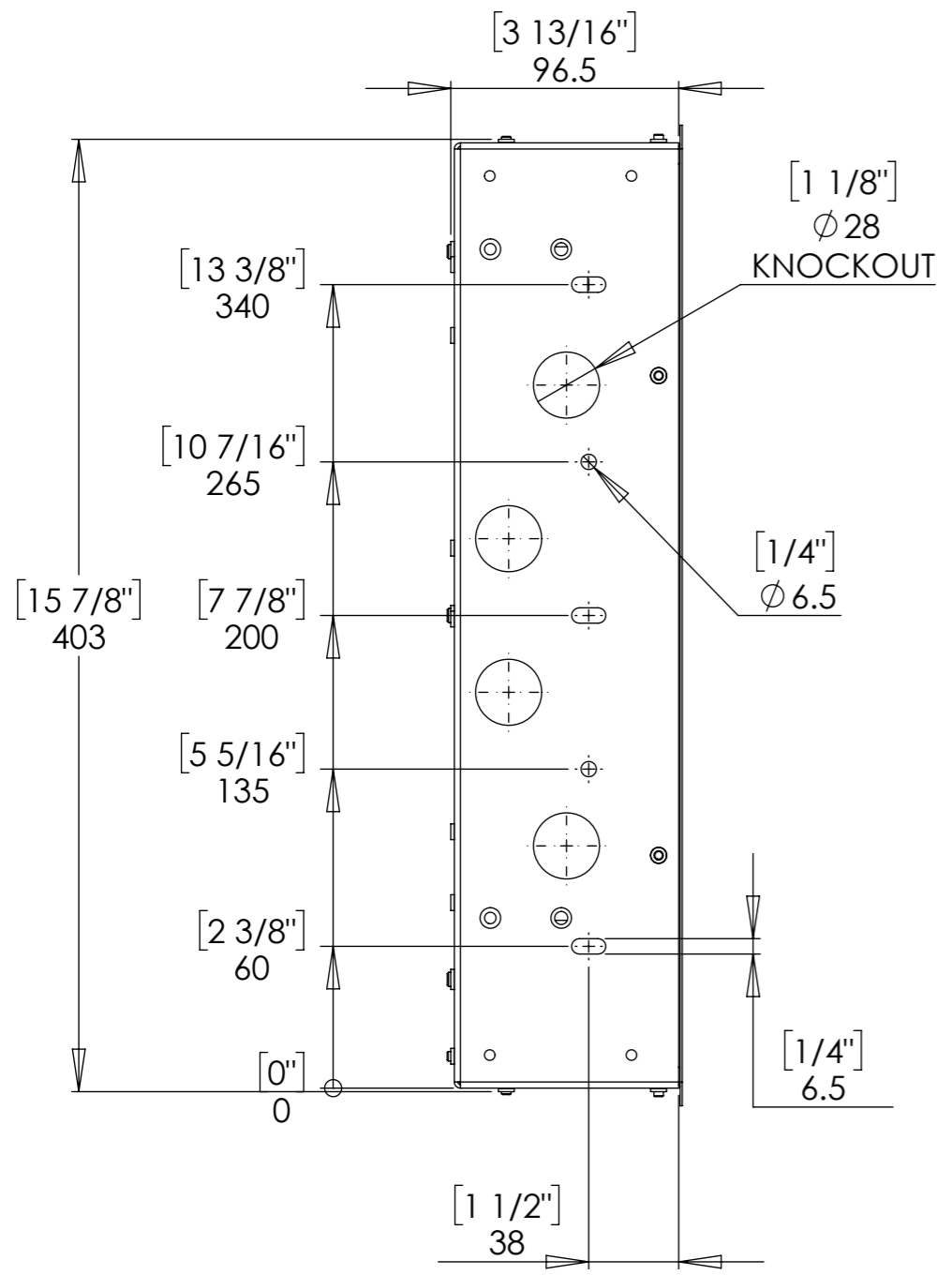

WB16-2S

WALL BOX 16 FOR TWIN STUD WIDTH

ACCESSORY MOUNTING FEATURES

The WB16-2S features adjustable accessory clamps and a large mounting spaces that means it is perfectly suited to a wide variety of AV accessories.

The removable plate and provided mounting brackets allow the WattBox WB-200/300VB to be mounted into the lower face of any size Wall Box.

- These include:
- Samsung One Connect
 - Power conditioners e.g BlueBolt SM-3 Pro
 - Baluns
 - Small audio converters
 - Apple TV
 - Roku
 - SnapAV OVRc compact power conditioner

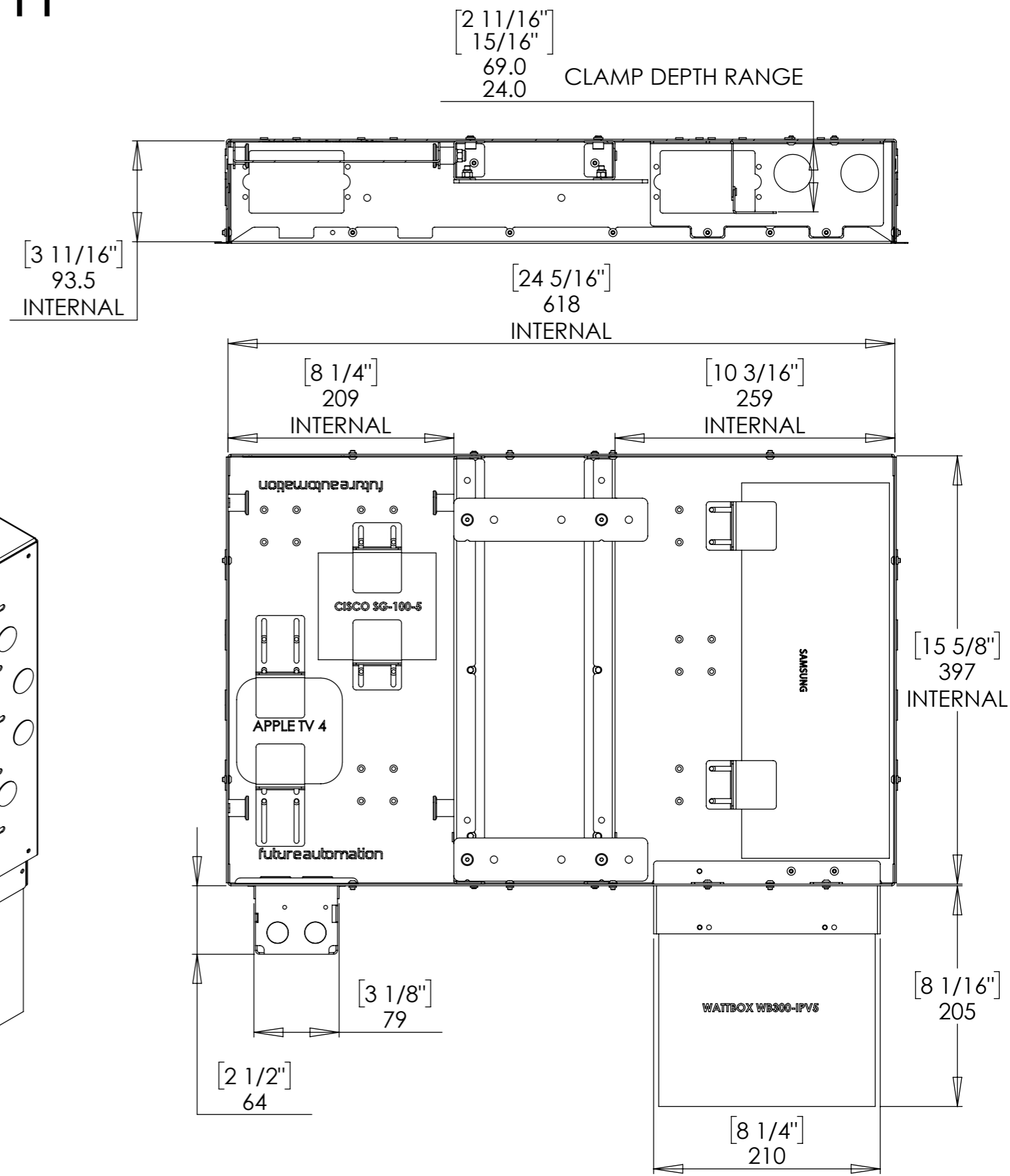
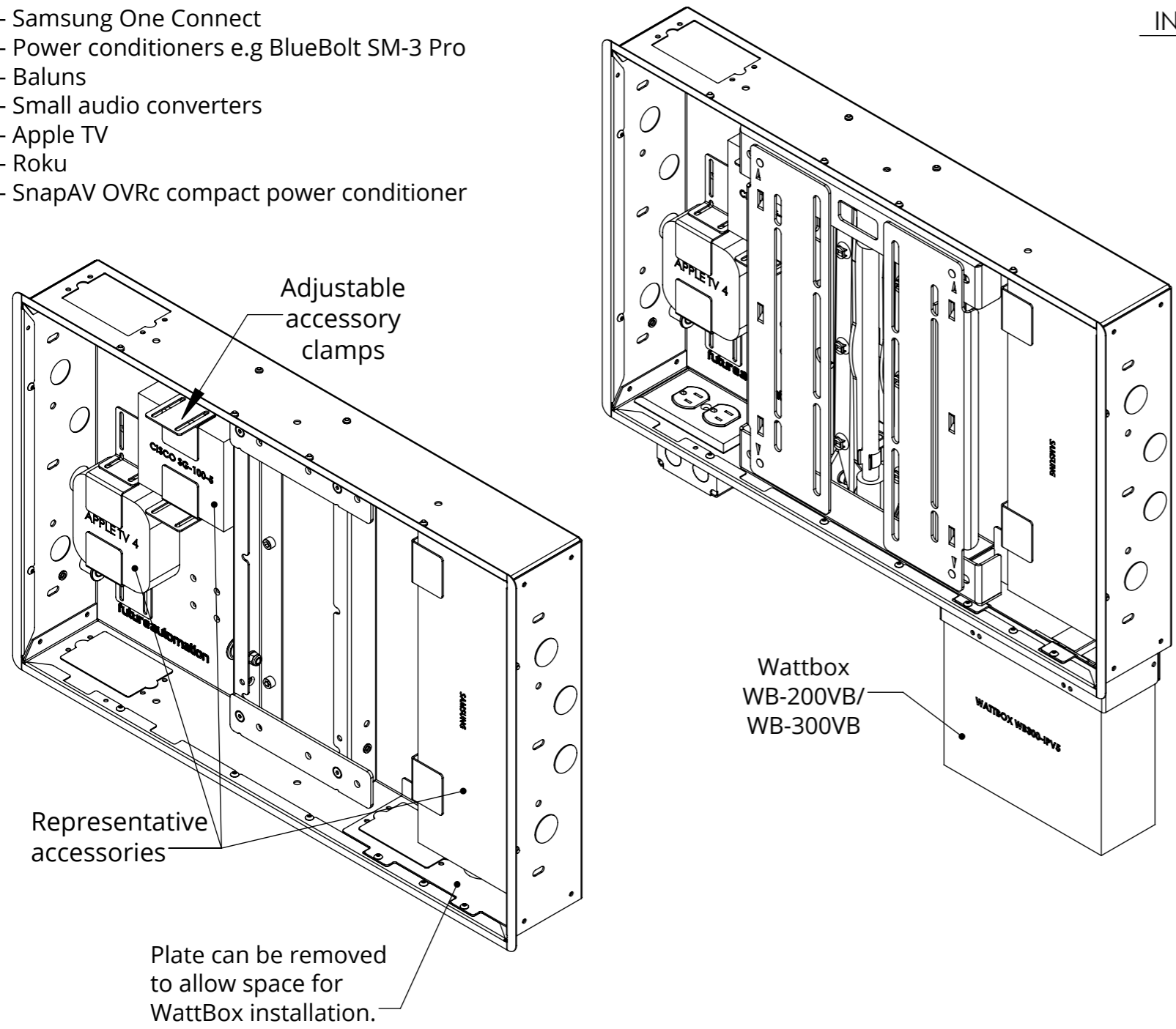

WB16-2S

WALL BOX 16 FOR TWIN STUD WIDTH

ACCESSORY MOUNTING FEATURES

The WB16-2S also features a removable accessory plate to which accessories can be cable tied. This plate has ONE fixed position to suit a wide variety of AV accessories.

The accessory plate is removed by pulling the top forward, and lifting out of the wall box. Accessories can be secured and cables routed before returning the plate.

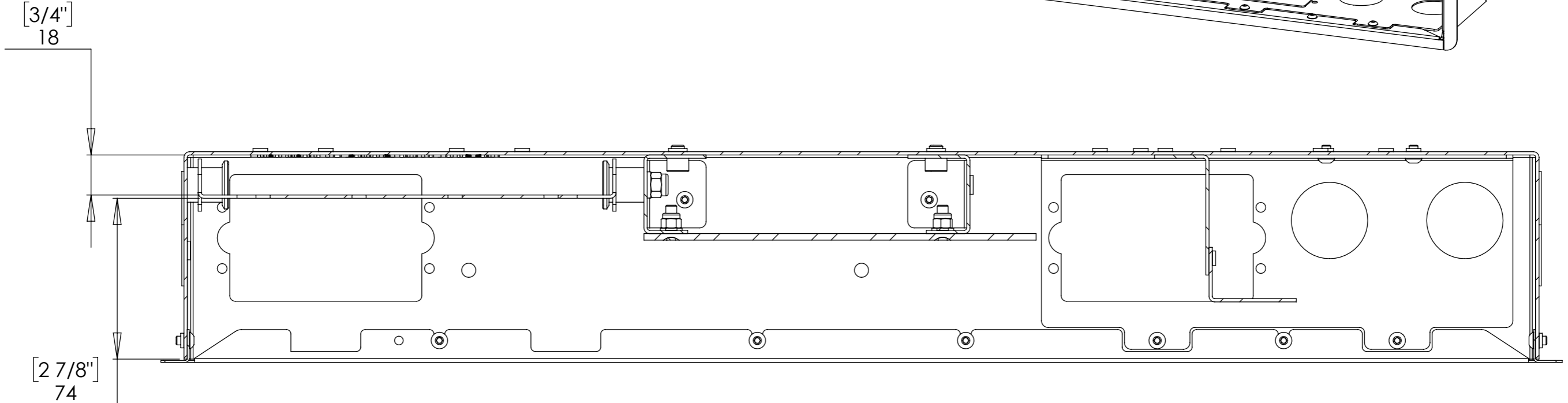
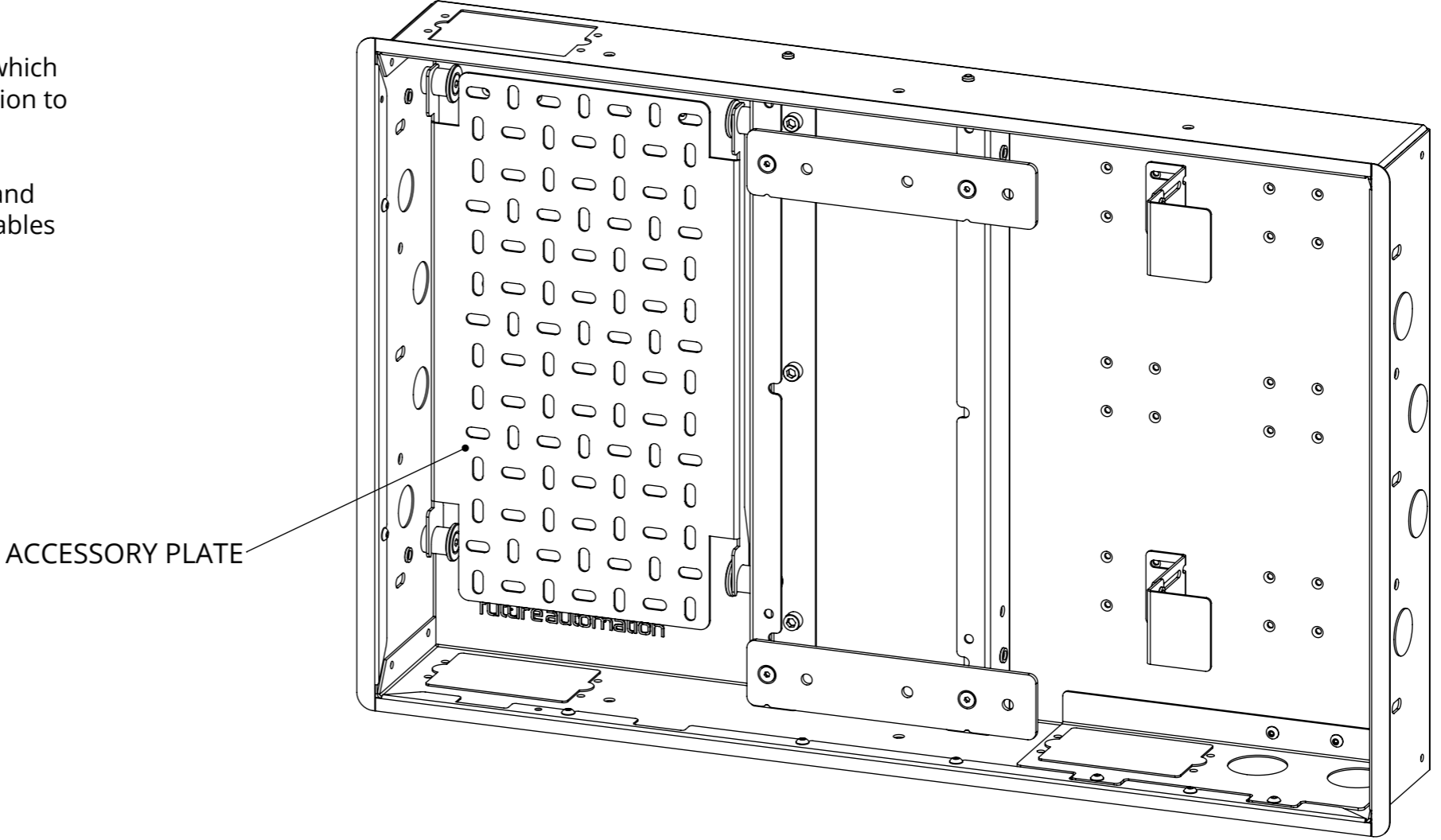

WB16-2S

WALL BOX 16 FOR TWIN STUD WIDTH



future automation

PS32 BRACKET MOUNTING

The PS32 has one central mounting position within the WB16-2S wall box.
There is NO lateral adjustment.

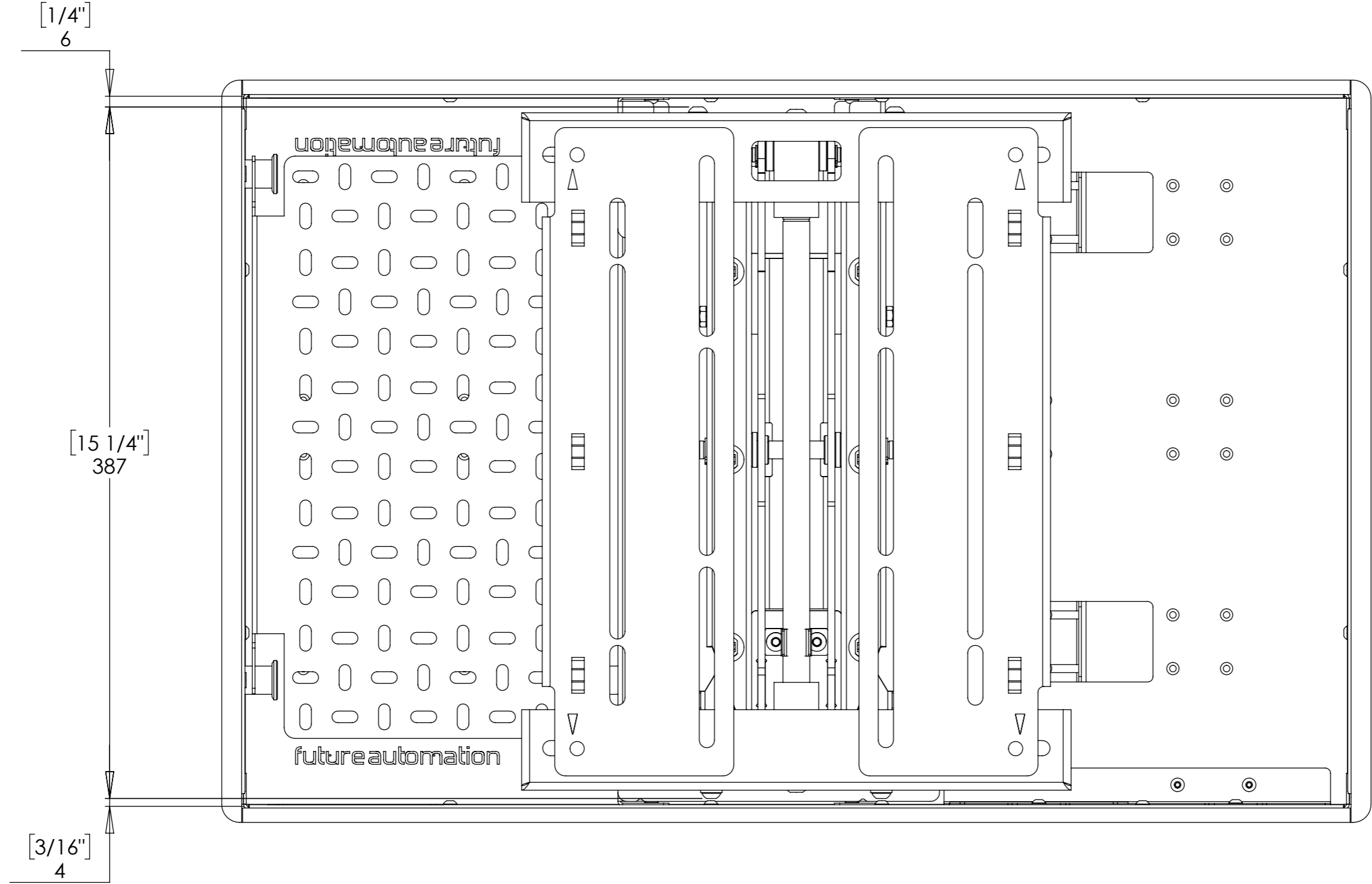

WB16-2S

WALL BOX 16 FOR TWIN STUD WIDTH



future automation

PS32 BRACKET MOUNTING

The WB16-2S comes with a pair of offset brackets for the PS32 to allow for VESA 400 height screen mounting.

This also enables the screen to be vertically offset to account for high/low bolt patterns.

