

WB QA2

WALL BOX FOR QA2

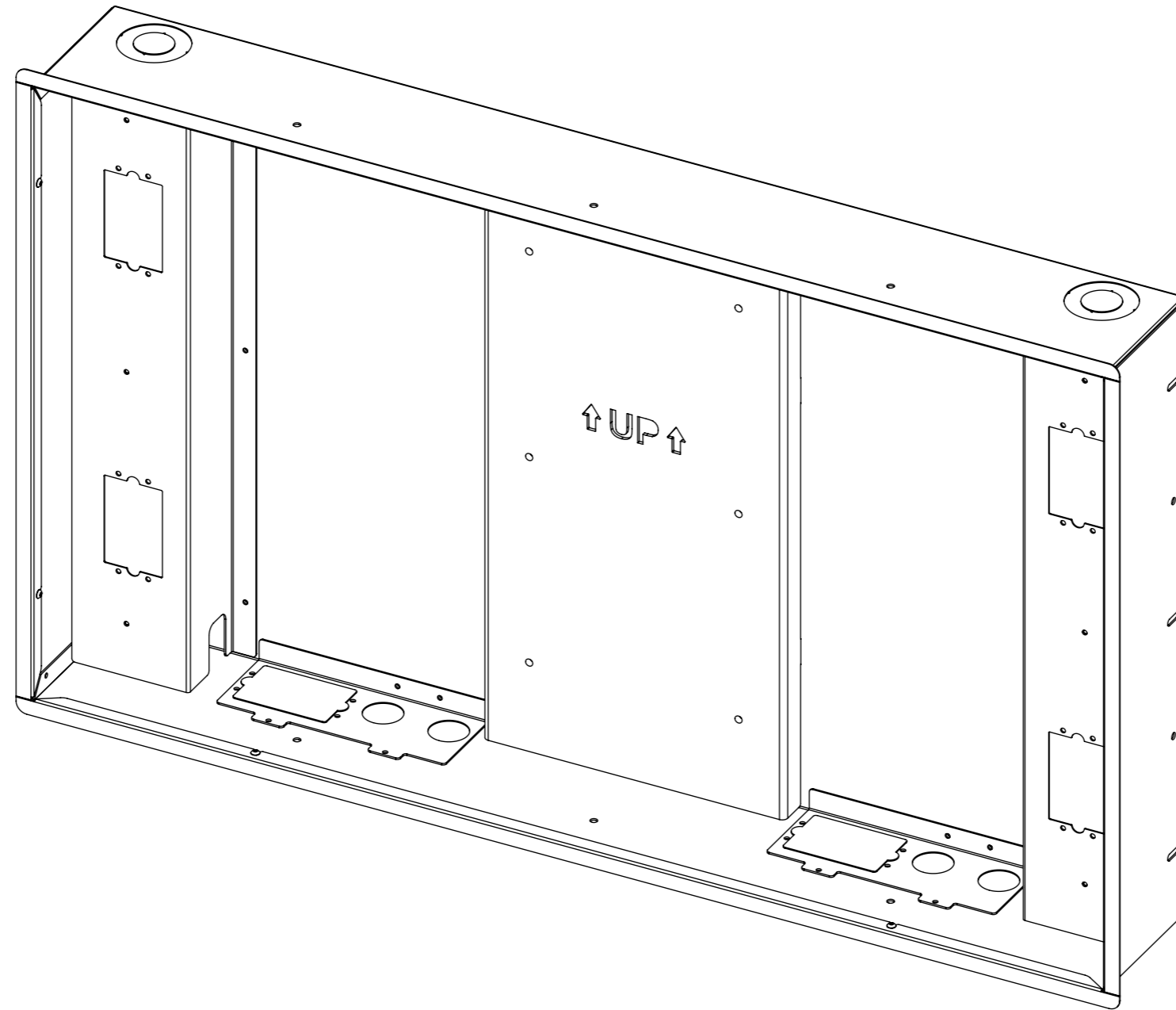

future automation



WB QA2

WALL BOX FOR QA2



future automation

SPECIFICATION	MEASUREMENTS
Product Dimensions	1041mm (41") x 627mm (24.7") x 147.5mm (5.8")
Maximum Weight Capacity	45Kg (99.2lb)
Product Weight	20.5Kg (45.2lbs)
Packaging Dimensions	TBC
Shipping Weight	TBC
Mounting Patterns Supported	VESA 400, 300, 200 W x 400, 300, 200 H
Package Contents	Mechanism
Marine Suitable	No

WB QA2

WALL BOX FOR QA2

QA2 DESIGN HIGHLIGHTS

Sophisticated electronics allow for a favourite viewing position to be programmed via the IR remote control.

The mechanism allows up to 644mm extension of screen centre from wall. Hook on removable uprights allow the bracket to take a wide variety of screens.

The arms on the right-hand side of the bracket conceal all power and signal cables.

QA2 IN WALL BOX

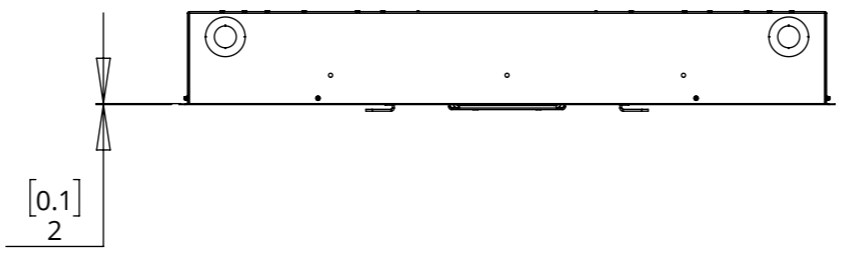

QA2 OUT - MAXIMUM EXTENSION

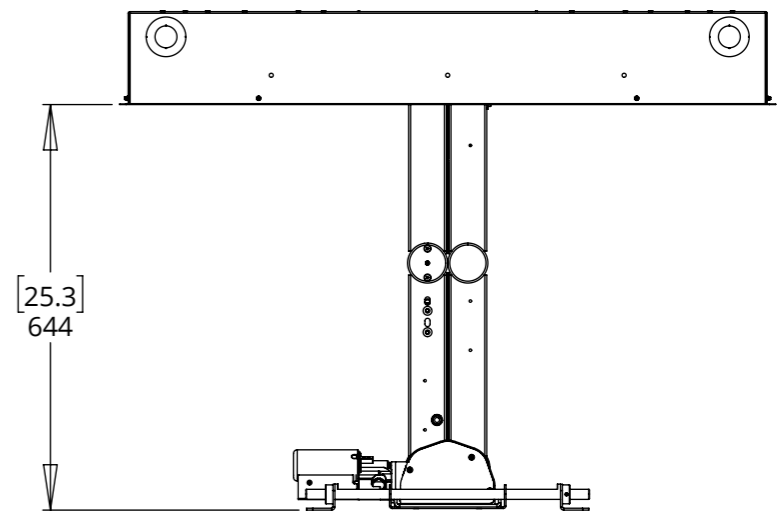

QA2 OUT - MAX LEFT SWIVEL

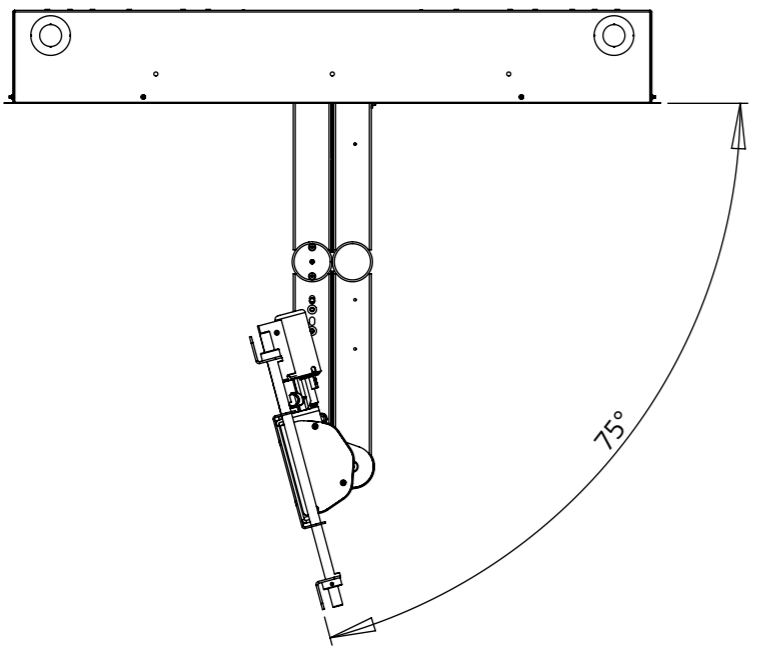

QA2 OUT - MAX RIGHT SWIVEL

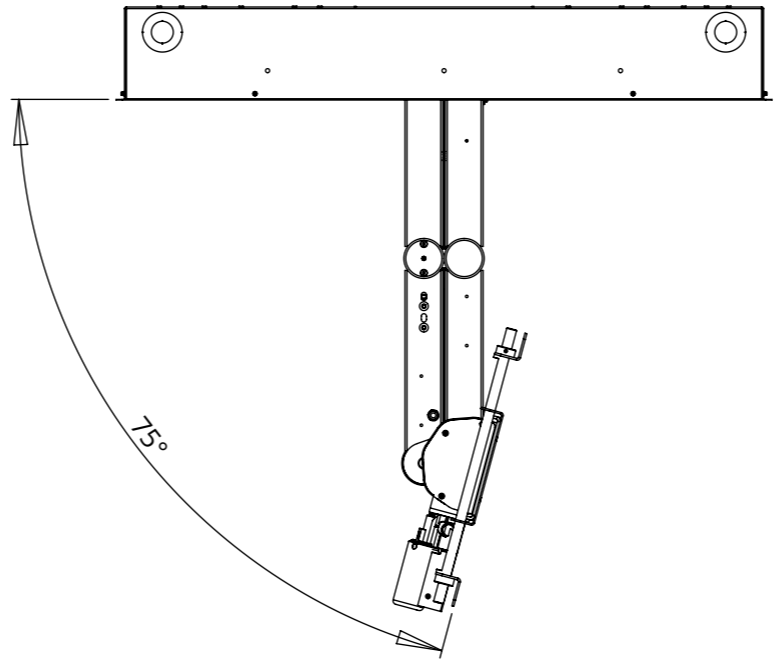

The bracket moves parallel to the wall to initially take the screen out of a tight recess before turning to the appropriate side.

WB QA2 WALL BOX FOR QA2

CABLE ROUTING

Route cable as shown, ensuring sufficient slack at moving points.

Use the knockout panels to install a junction box and/or pass the cables through the wall box into the wall cavity.

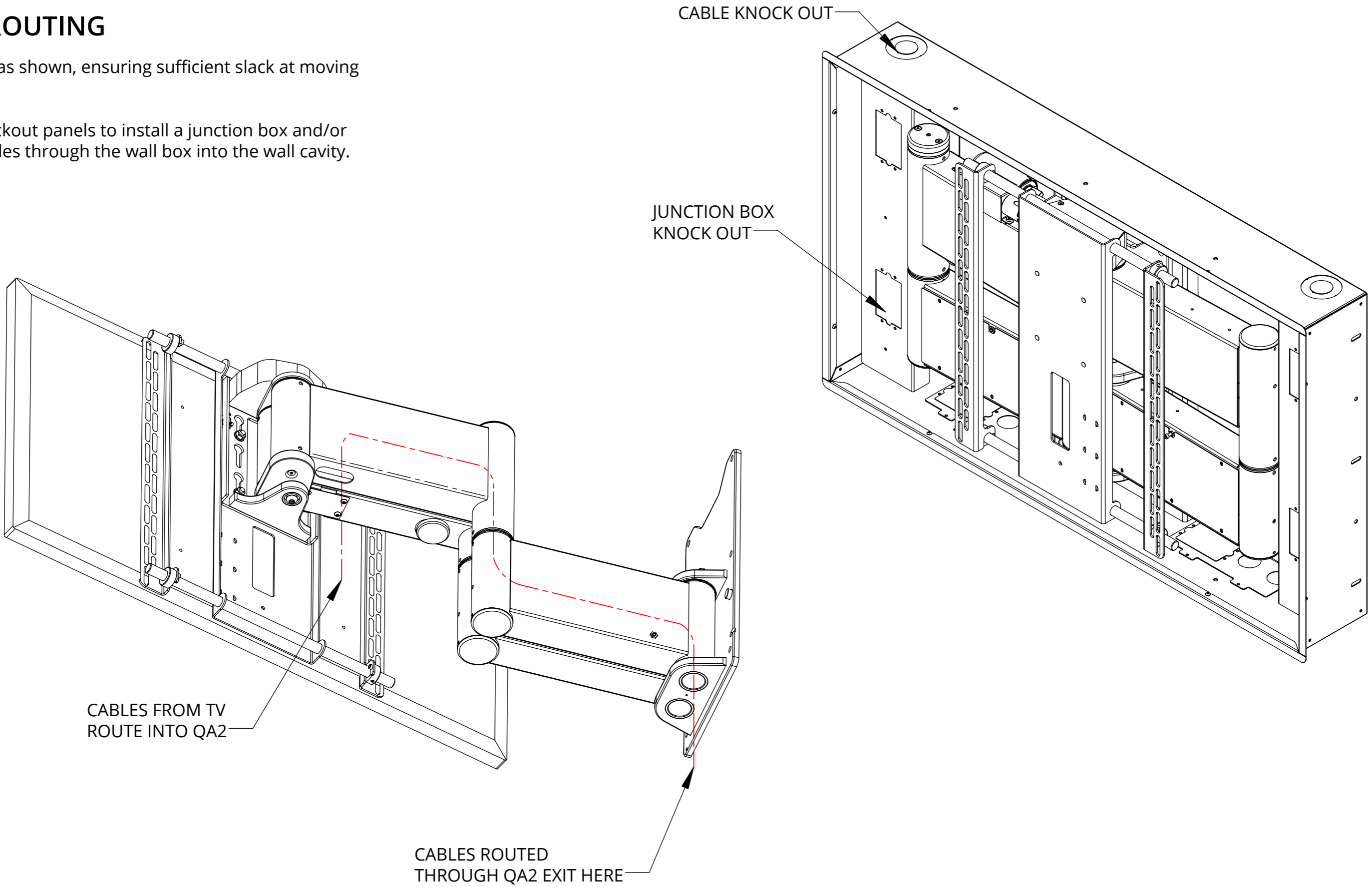

WB QA2

WALL BOX FOR QA2

WALL BOX MOUNTING DIMENSIONS

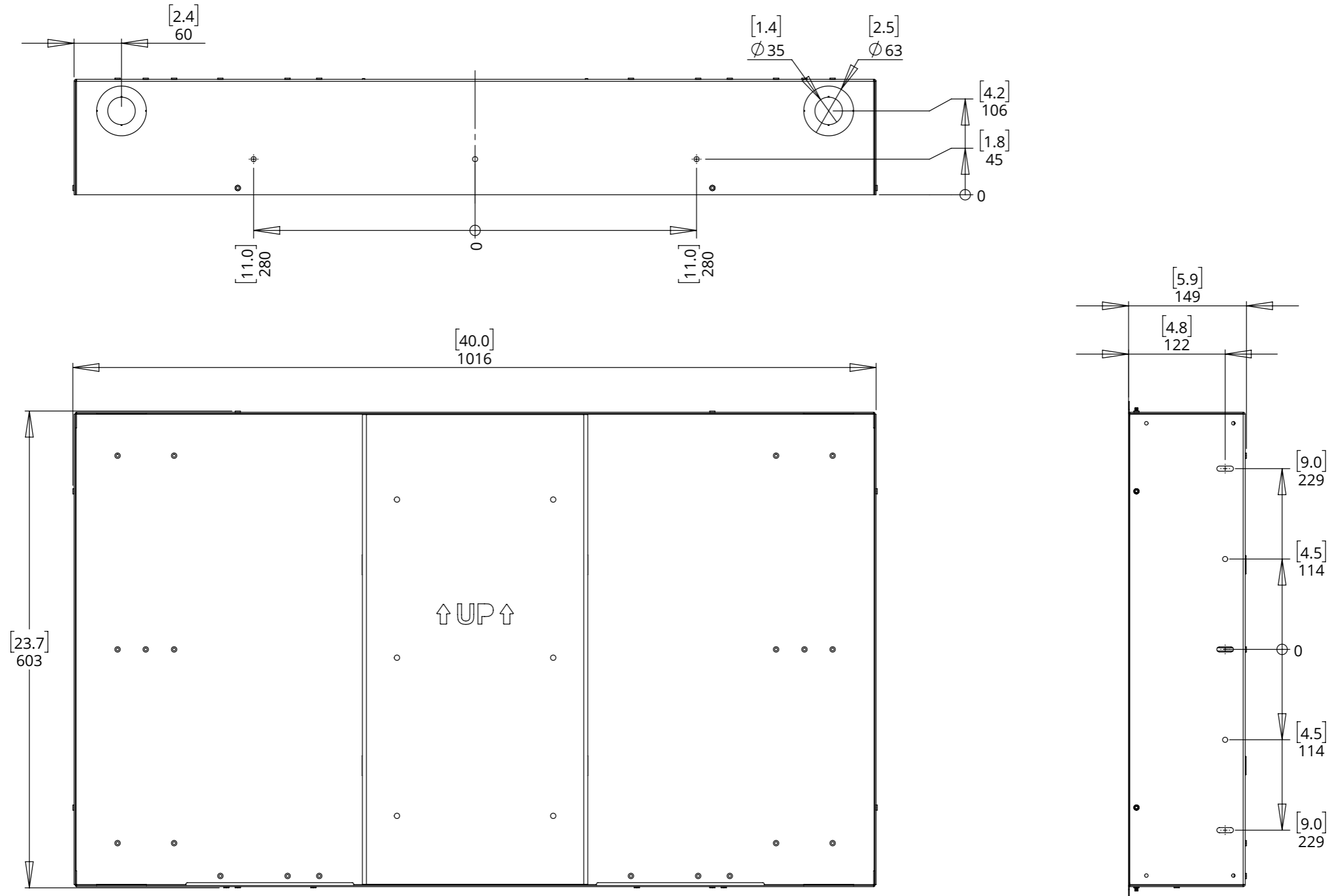

WB QA2

WALL BOX FOR QA2

GENERAL DIMENSIONS

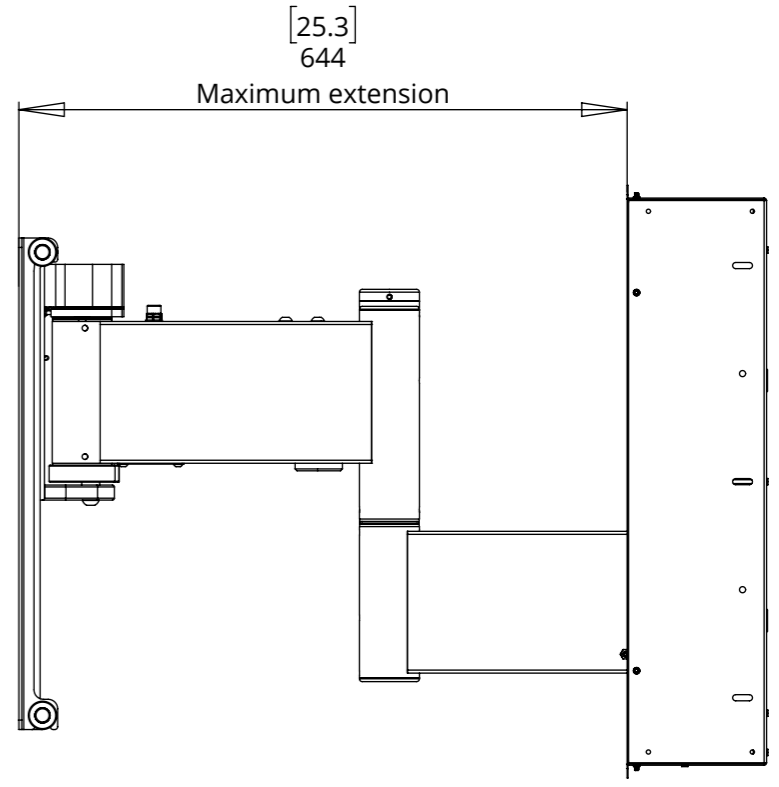
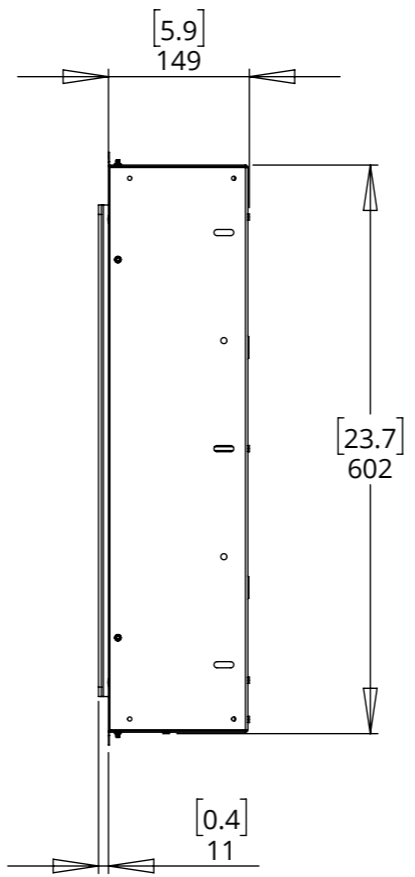
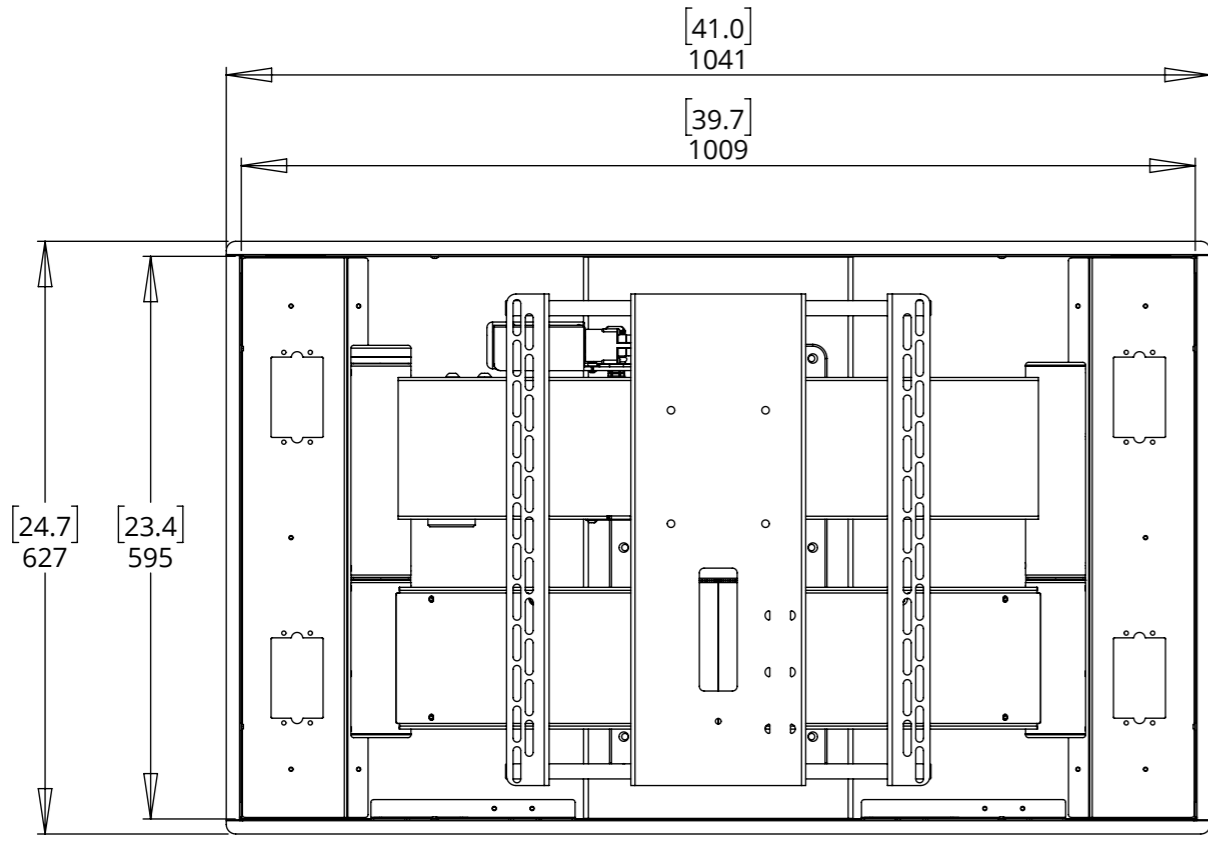
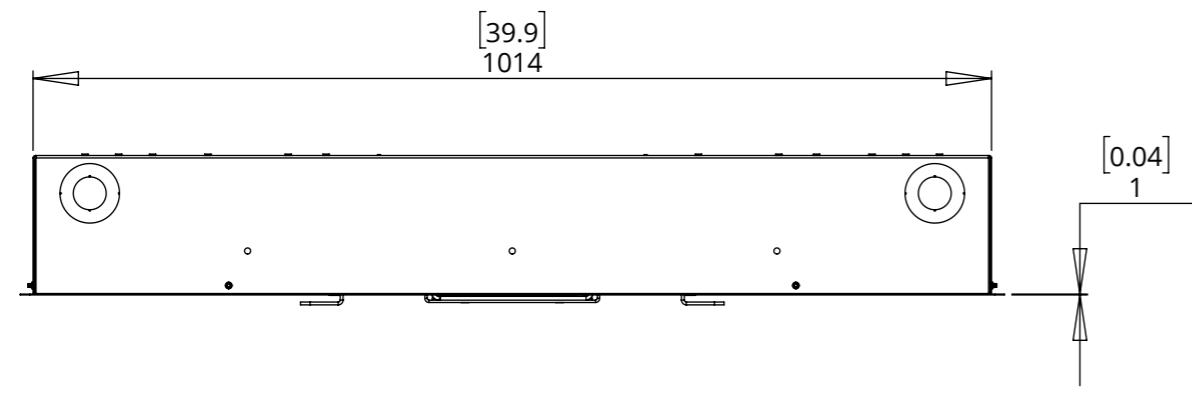

WB QA2

WALL BOX FOR QA2

ROTATION ANGLE

With the installation of the Wall Box, the QA2 wall plate is recessed back into the wall by 118mm [4.7"]. In turn this decreases the maximum viewing angle rotation for varying sized screens.

Below is a guide to the viewing angle achieved with different screen sizes, shown with the wall.

55" SCREEN

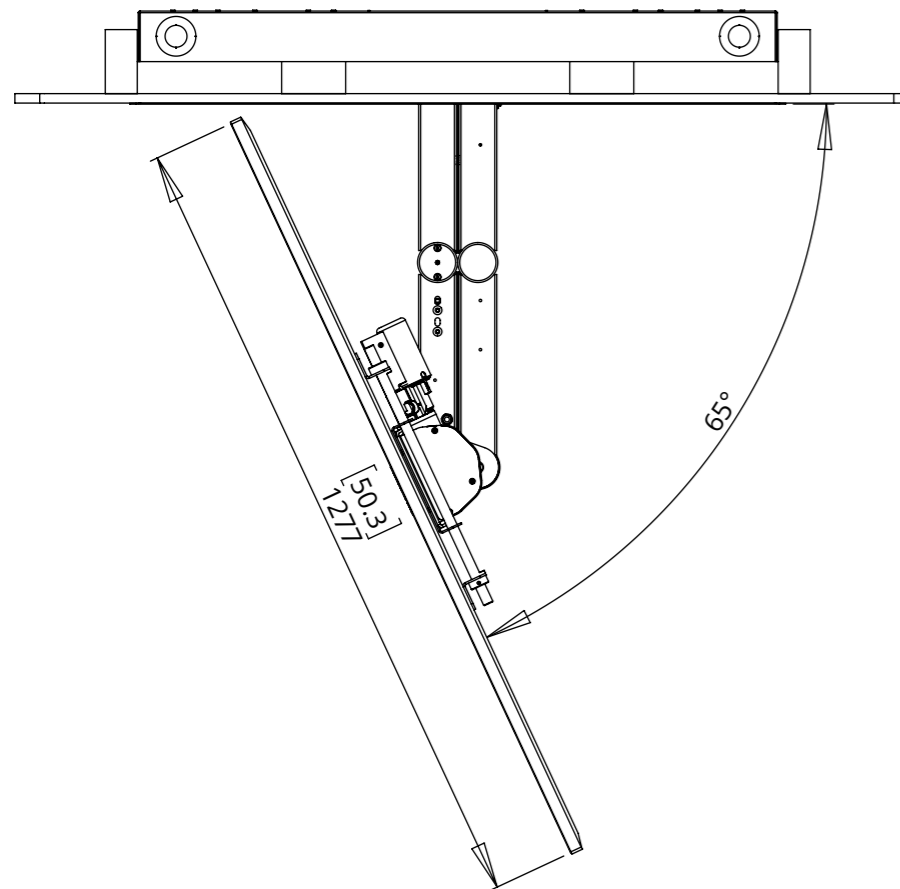

65" SCREEN

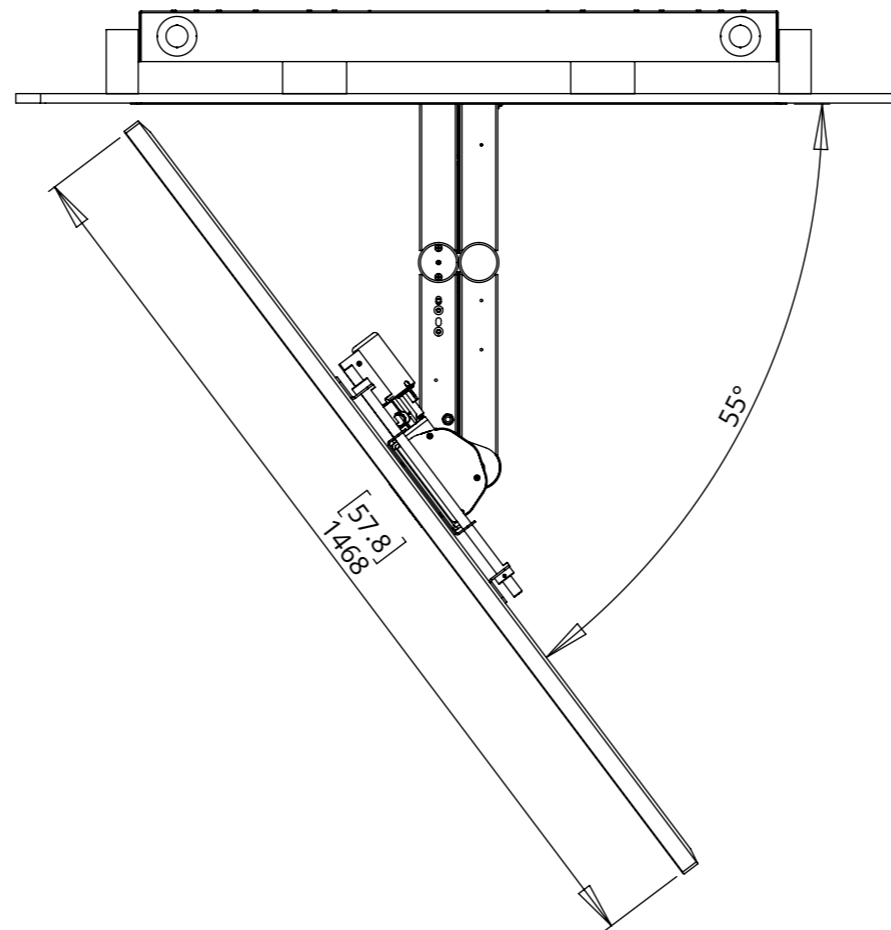

75" SCREEN

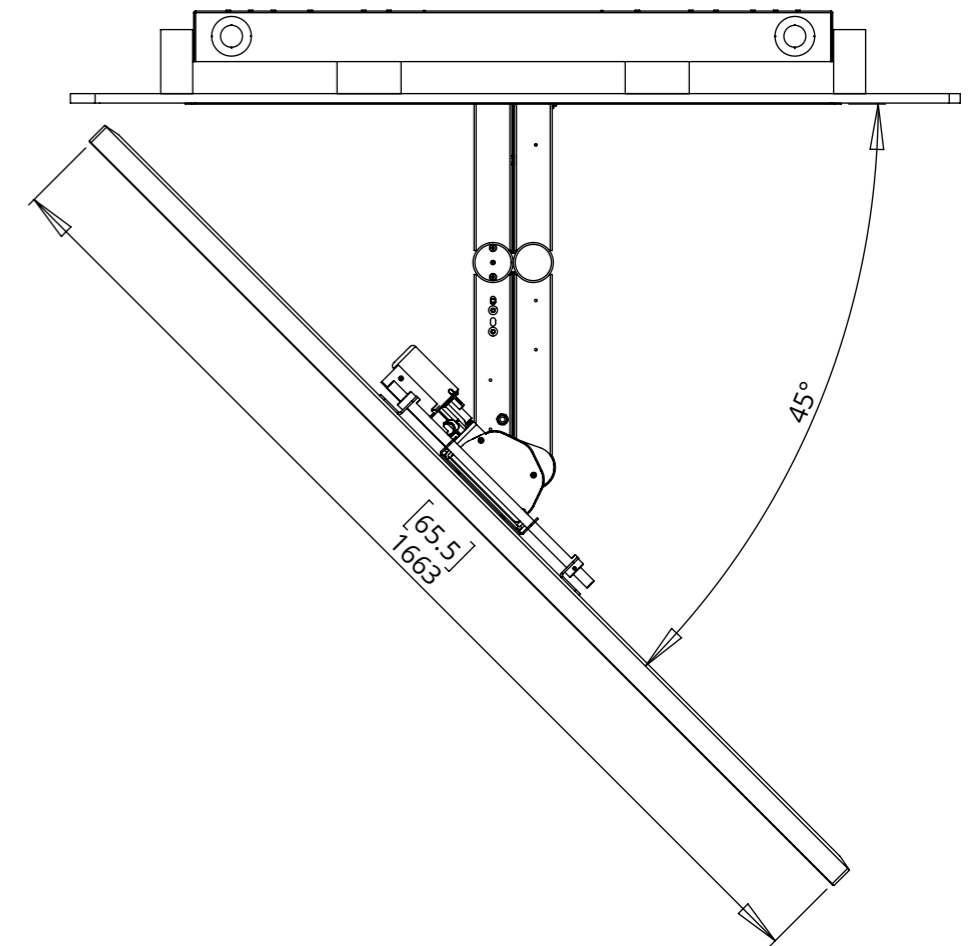

WB QA2

WALL BOX FOR QA2



FRAMING DETAILS

Shallow horizontal studding should be used when framing the Wall Box. This allows for cables and a watt box to be fitted within the wall, and pass through both the grommet holes and the panel cut outs in the box - shown on the Section View.

The studding either side of the wall box should be deeper to allow for secure fixing of the wall box.

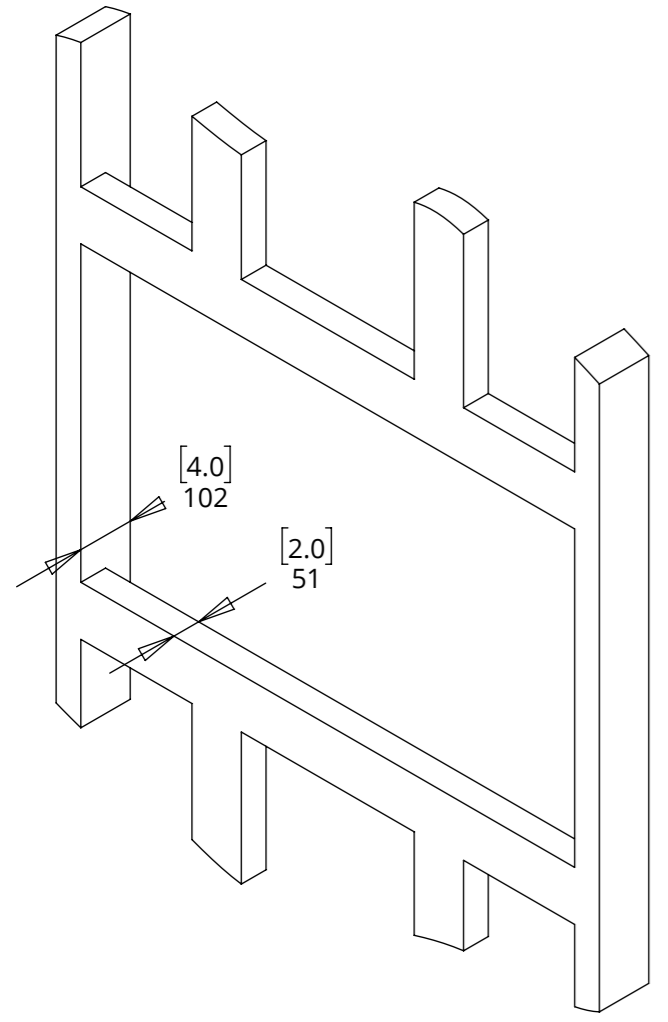

WALL STUDDING

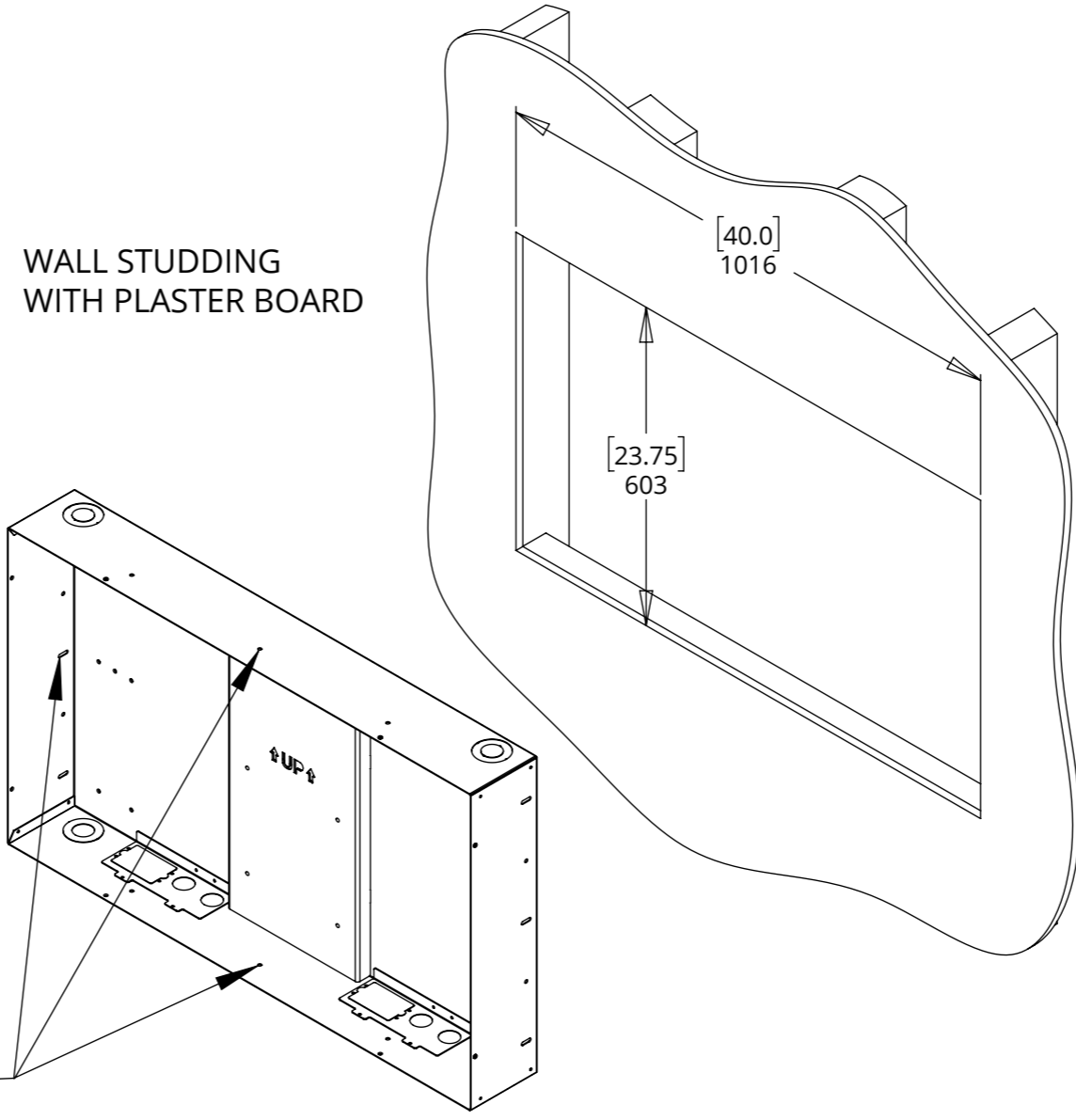

WALL STUDDING WITH PLASTER BOARD

INSERT WALL BOX INTO RECESS AND SECURE THROUGH FIXING HOLES

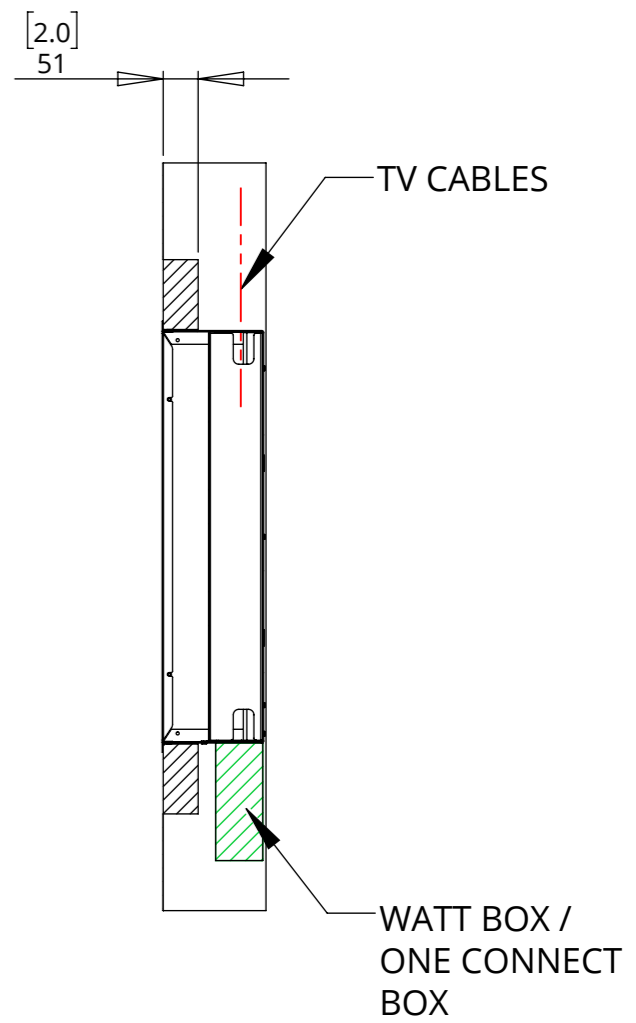

SECTION VIEW

WB QA2

WALL BOX FOR QA2



future automation

