

# WB-DA2

## WALL BOX FOR DA2

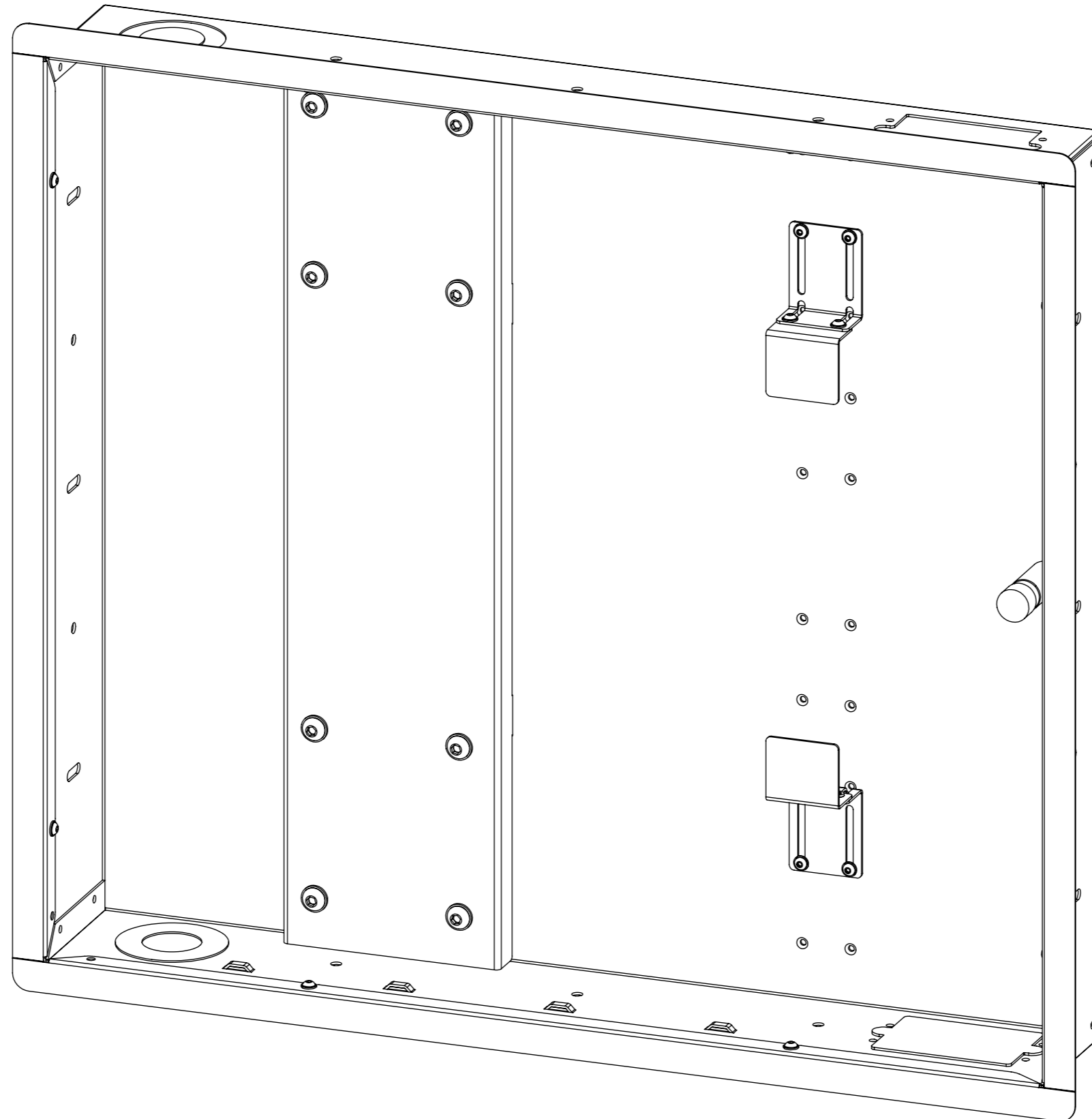

future automation



# WB-DA2

## WALL BOX FOR DA2



future automation

SPECIFICATION	MEASUREMENTS
Product Dimensions (WxHxD)	661mm (26 1/2") x 597mm (23 1/2") x 99mm (3 7/8")
Product Weight	9kg (20lb)
Packaging Dimensions	880mm (34 5/8") x 800mm (31 1/2") x 220mm (8 11/16")
Shipping Weight	10kg (22lb)
Mounting Patterns Supported	VESA 400, 300, 200, 100 W x 400, 300, 200, 100 H
Product Options / Features	Specific B&O and Loewe mounts / adapters, Custom RAL paint finishes
Package Contents	1x Wall Box, 1x Pair of Accessory Clamps, 1x Buffer Stop, 2x Horizontal Wall Trim Strips , 2x Vertical Wall Trim Strips & Bolt Pack
Marine Suitable	No

# WB-DA2

## WALL BOX FOR DA2

### ACCESSORY MOUNTING

The WB-DA2 features easily adjustable accessory clamps and mounting space for AV accessories.

To access the mounting space, the DA2 must first be moved to the out position.

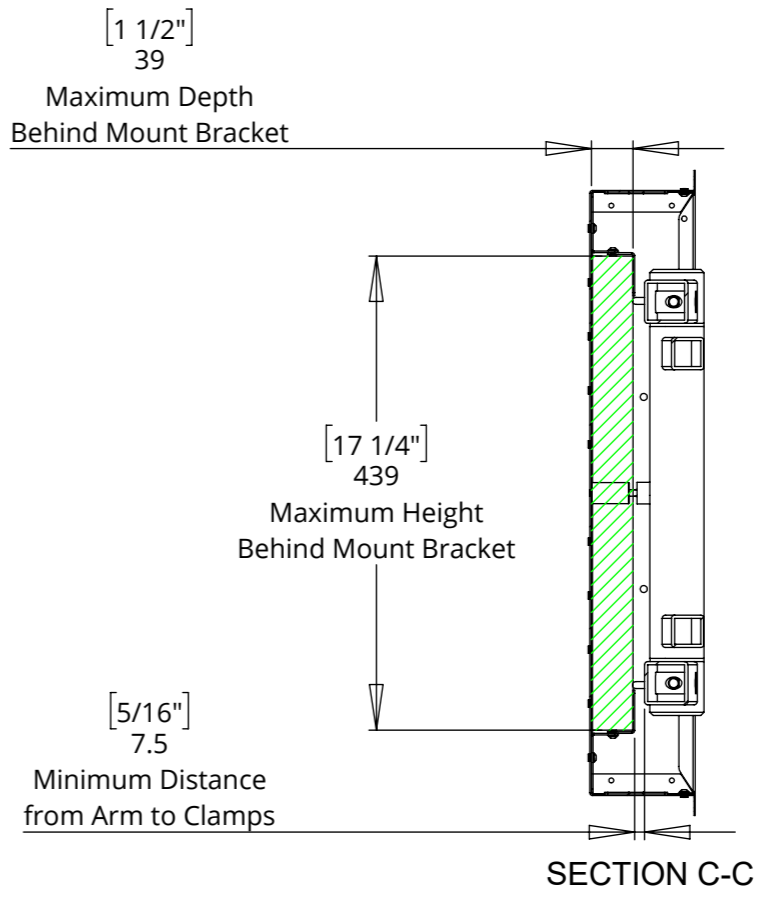
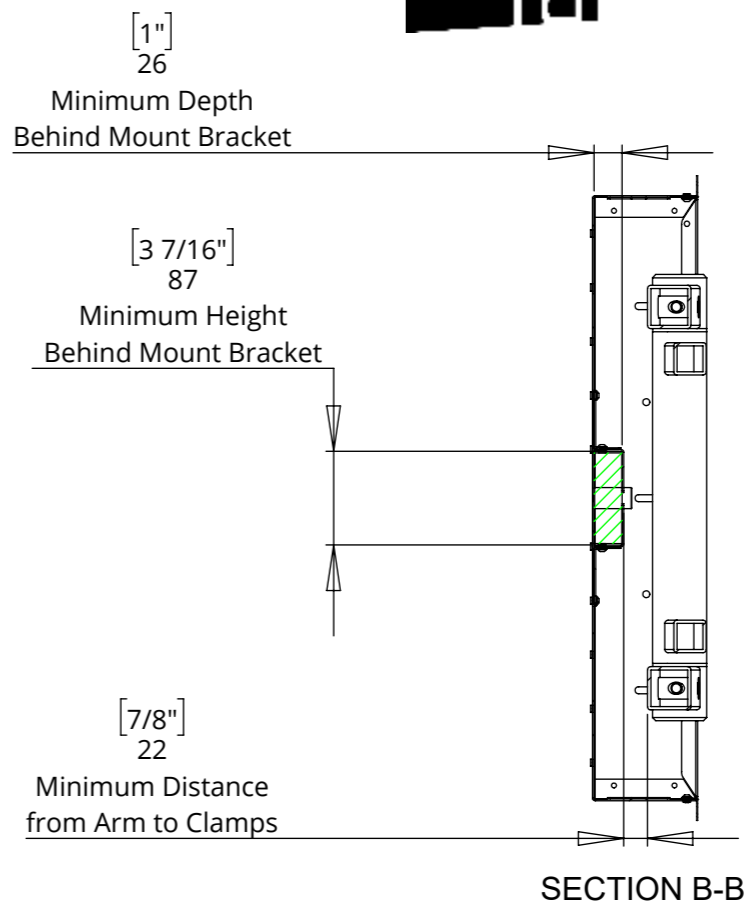
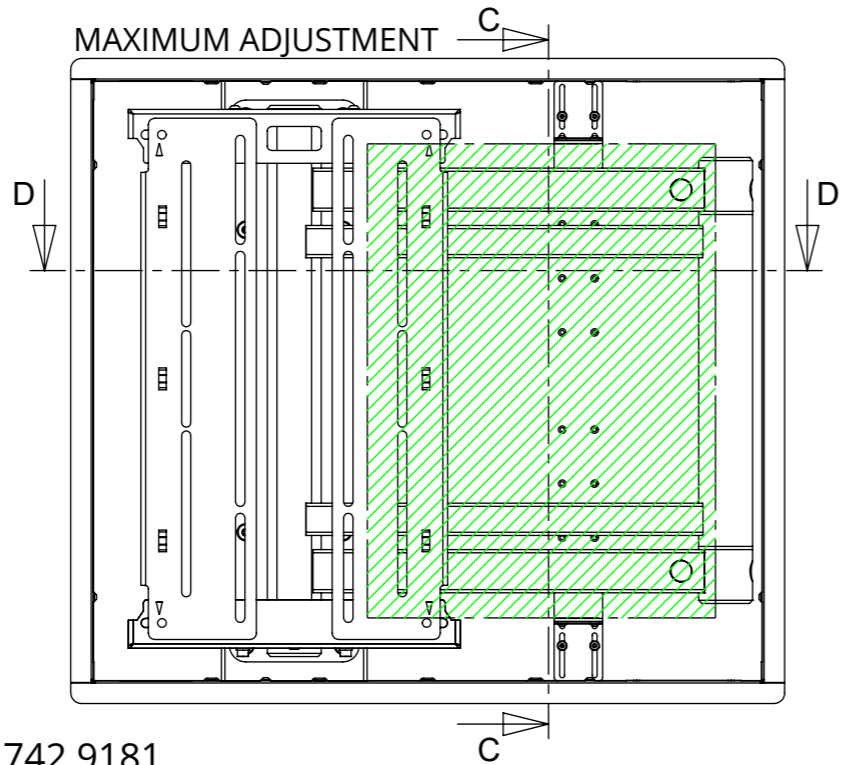
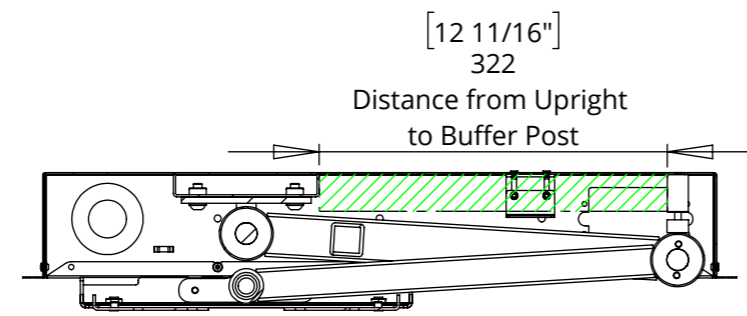
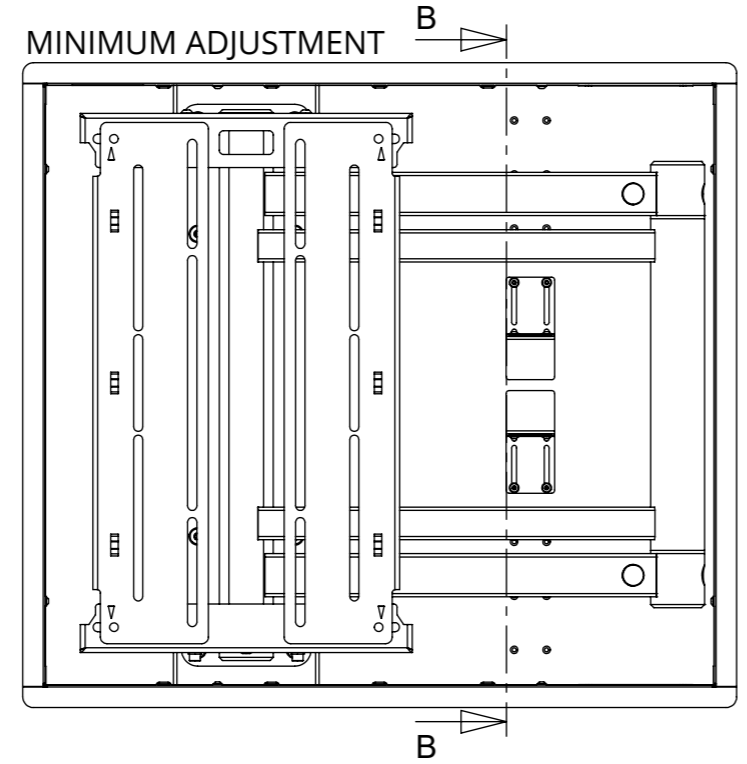

# WB-DA2 WALL BOX FOR DA2

## CABLE ROUTING

Cables can be run along the top or bottom arms as shown.  
Secure the cables using cable ties and make sure to allow slack at pivot points.

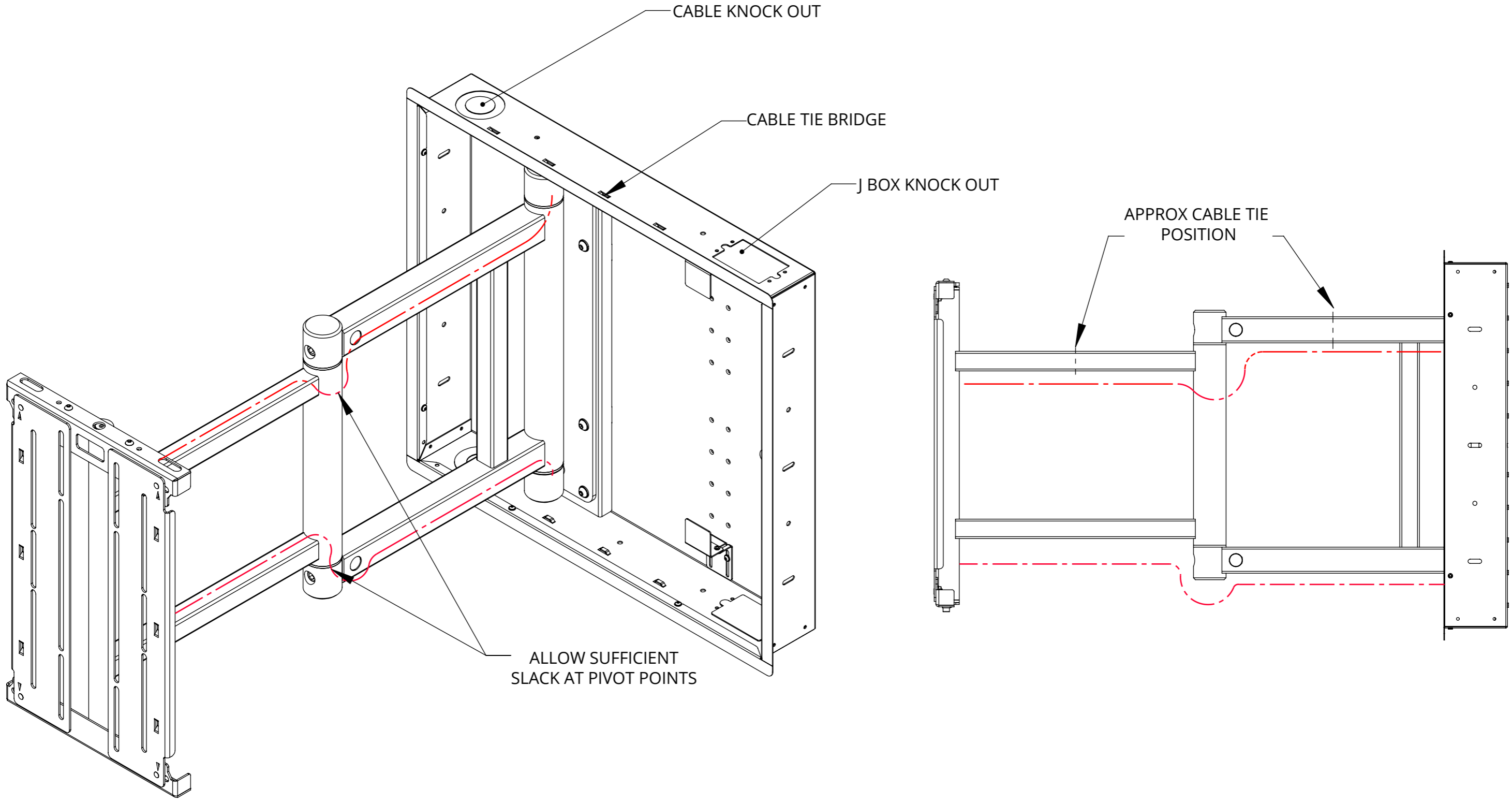

# WB-DA2

## WALL BOX FOR DA2

### GENERAL DIMENSIONS

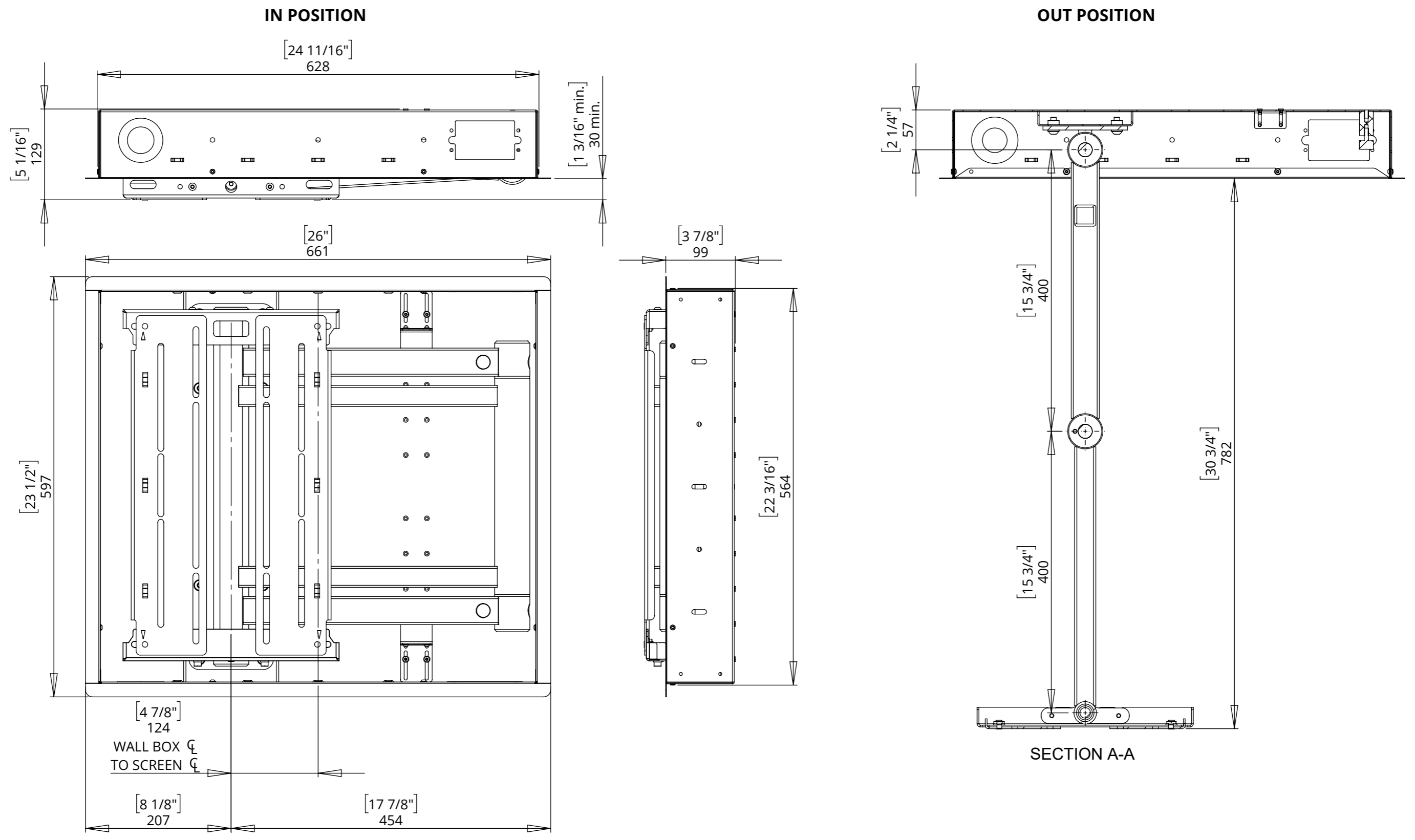

# WB-DA2

## WALL BOX FOR DA2

### WALL BOX MOUNTING DIMENSIONS

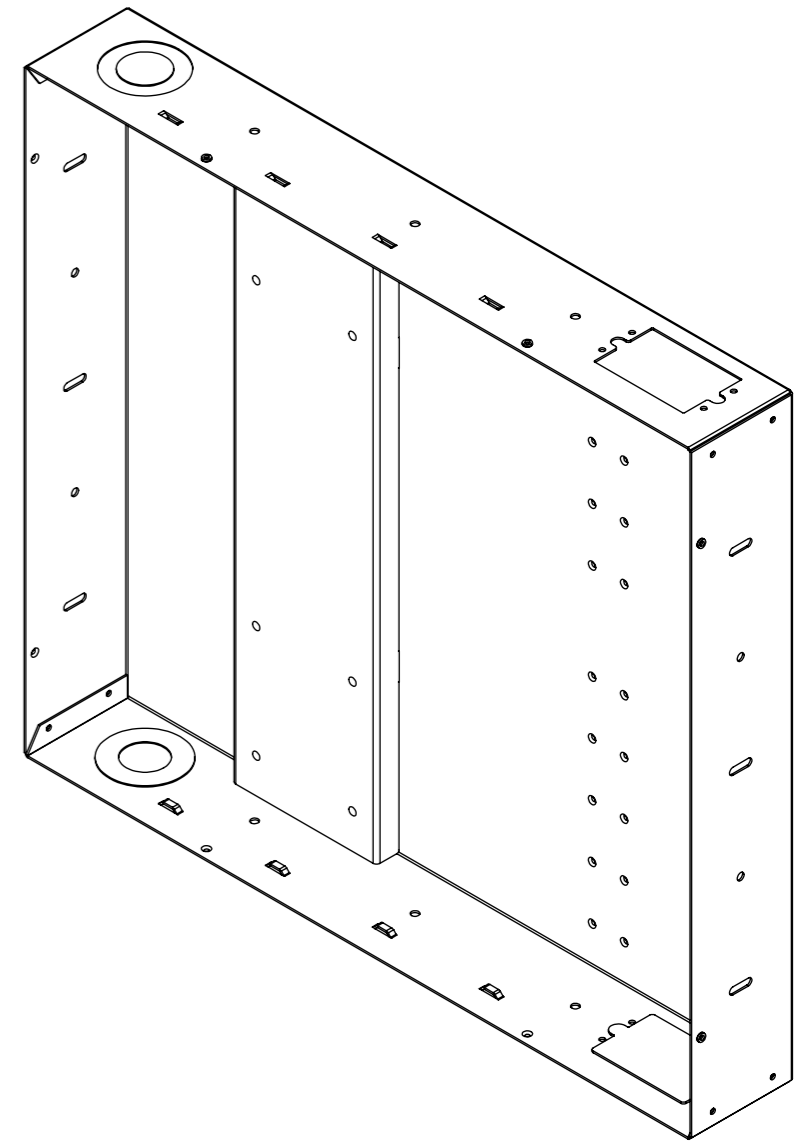
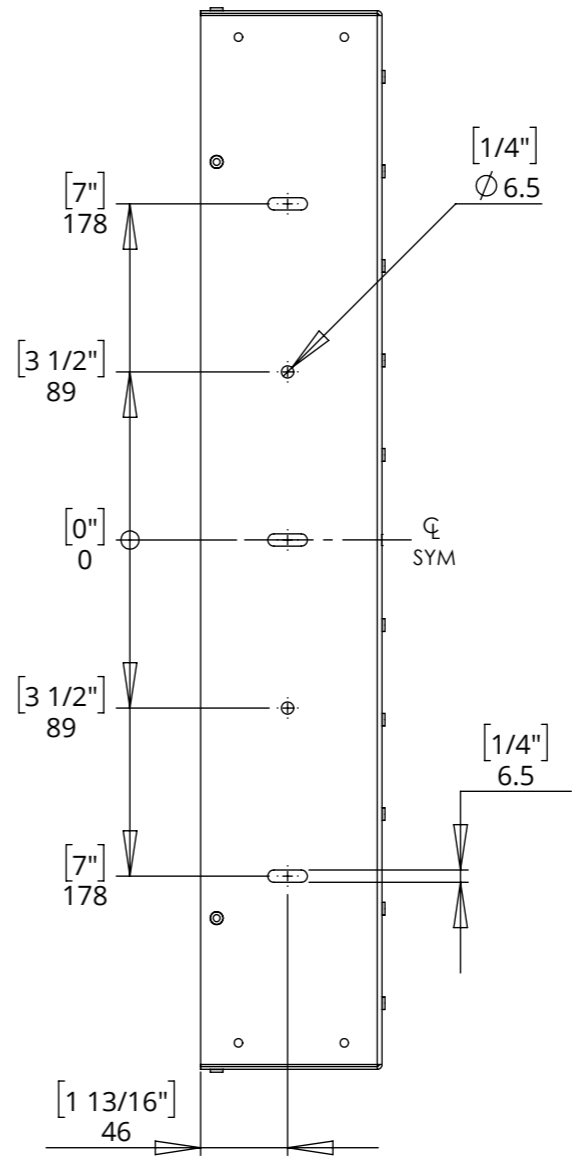
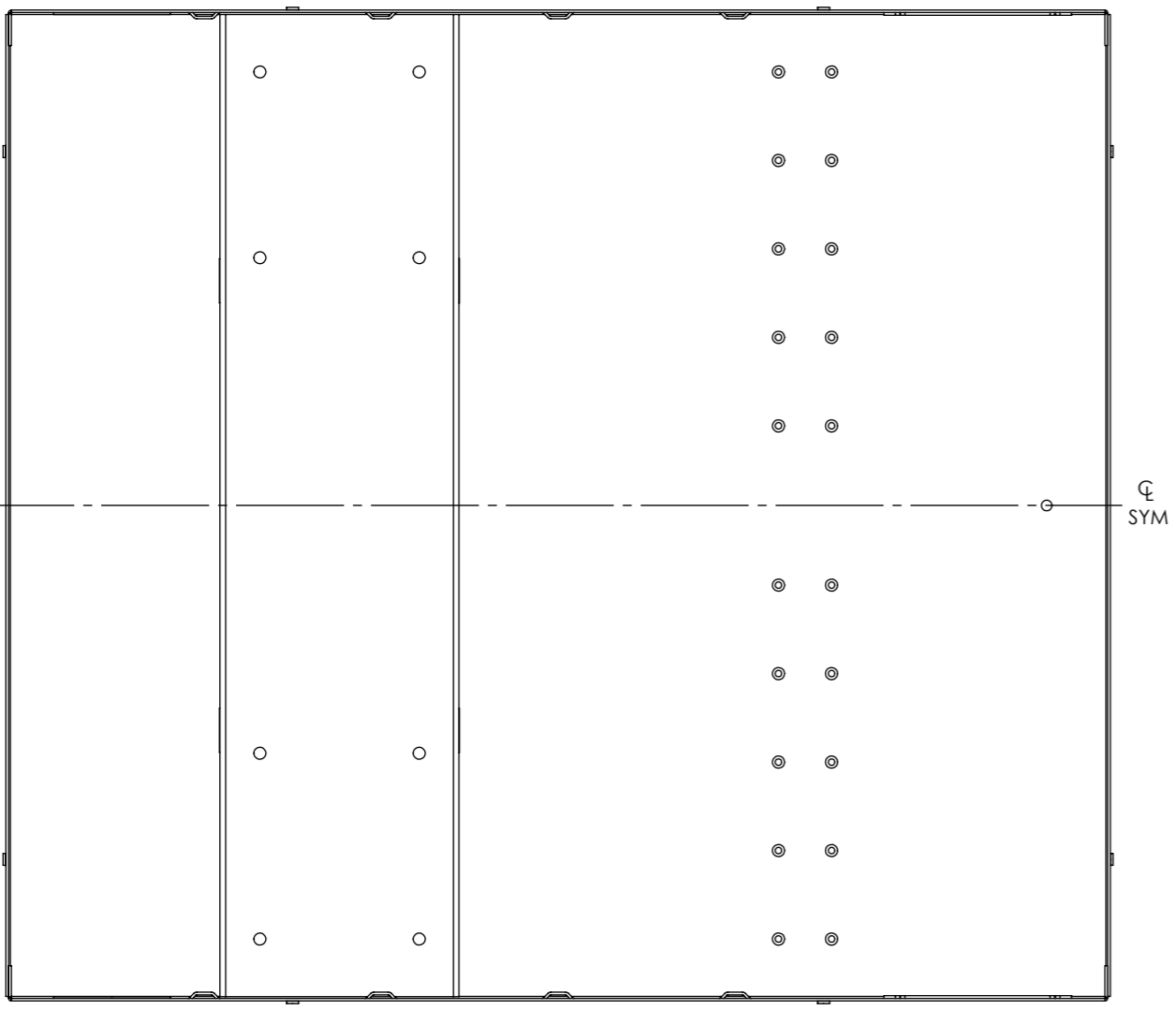
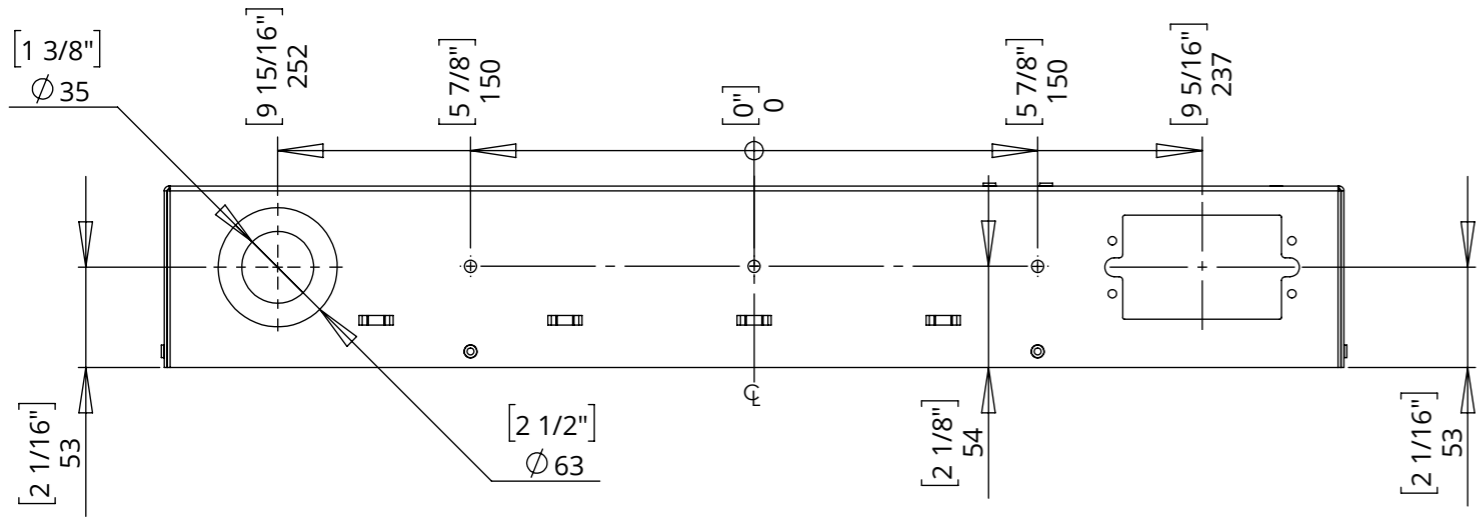

# WB-DA2

## WALL BOX FOR DA2



### WALL FRAMING DIMENSIONS

Horizontal studs should be used, with the Wall Box fixed through the three top and three bottom fixing holes.

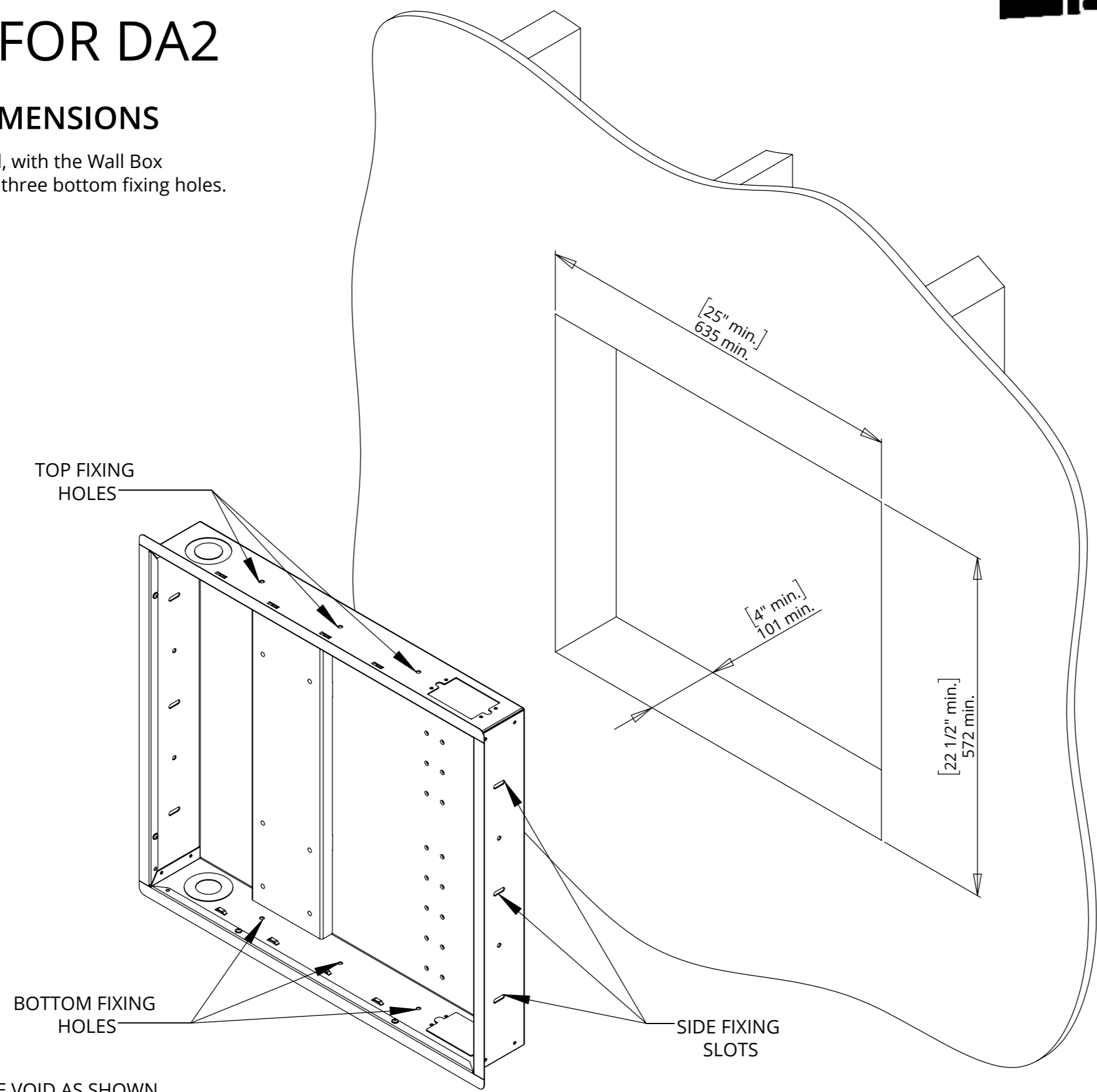

INSERT THE WALL BOX INTO THE VOID AS SHOWN THEN SECURE THROUGH FIXING HOLES