



Scan to view manual in additional languages

INTRODUCTION

Thank you so much for choosing the KLH Model Three™ loudspeaker. KLH's Model Three is an innovative, compact system that rivals the largest loudspeakers. The mid-century modern speaker reflects the iconic styling and musical integrity unique to the KLH brand while providing a solution for music enthusiasts with smaller listening spaces. Built on the acoustic suspension design principle, advanced technology, the finest materials, and sophisticated quality control, the Model Three guarantees to provide you with unparalleled listening pleasure for many years to come.

To achieve the level of music reproduction Model Three's are capable of requires care in both installation and operation. If you are new to the audiophile world, please take the time to read this manual and follow the instructions. You will be happy you did!

THE HISTORY OF KLH & THE MODEL THREE

KLH Audio was established in 1957 by Henry Kloss, Malcolm Low, and Josef Hofmann. Henry Kloss first made his name in Acoustic Research with the AR-1 and its patented acoustic suspension system that revolutionized the high-fidelity industry. Kloss later left Acoustic Research to start KLH, where he immediately began marketing his acoustic suspension loudspeaker designs.

Throughout the 1960s and 1970s, KLH was the top seller for acoustic suspension loudspeakers. Several models were very successful during that time and continue to be held in high regard for their tonal accuracy and precision today. The KLH Model Three is an all-new acoustic suspension loudspeaker model, first introduced in 2022. This loudspeaker will carry on the legacy of accurate audiophile-quality performance while delivering great value to the customer.

ACOUSTIC SUSPENSION DESIGN

First introduced in 1954, the acoustic suspension principle has long been considered the most accurate of all loudspeaker designs. The original AR-1, the well-known AR-3, and various later models were all brought to market by Edgar Villchur and Henry Kloss. Several brands, including KLH, would adopt the acoustic suspension principle and use it in their loudspeakers designs for many years to come. This design principle dominated the speaker market well into the 1970s.

In an acoustic suspension design, the air volume inside the enclosure serves as a cushion of air, or air spring, to provide a restoring force for the woofer cone. The said air inside the enclosure becomes the dominant part of the woofer's suspension. Because the air volume inside the enclosure is more linear than the mechanical parts of the woofer's suspension, the woofer's diaphragm can move more linearly. This linear movement enables the driver to operate at higher excursions with less distortion than traditional bass-reflex systems. Acoustic suspension systems receive worldwide praise for their greater accuracy, tighter bass transients, and exceptional bass resolution and texture.

TWO-WAY DESIGN

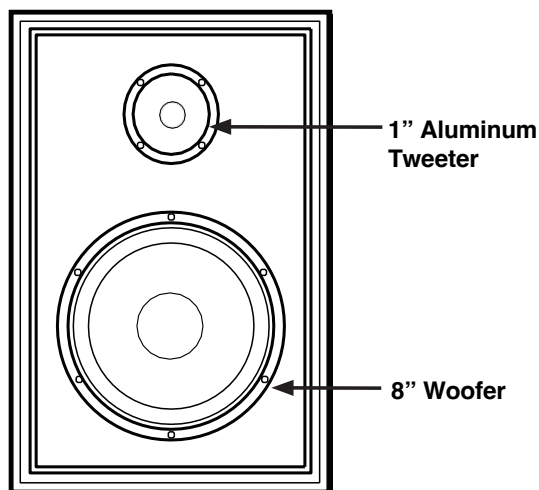

The KLH Model Three is a compact, 2-way system that provides full-range sound to average-sized listening spaces. KLH designed an 8" woofer specifically for this 2-way system, and it features a smooth and extremely accurate response up to 1,600 Hz. This woofer delivers clear vocals and offers rich reproduction of lower midrange instruments- all while minimizing distortion. Meanwhile, the 1" tweeter provides a smooth extended response with low distortion. The dispersion characteristics are polished and natural, which is crucial for a large and accurate stereo image.



WHAT IS IN THE CARTON?

The carton contains one Model Three speaker, one grille, one slant riser base, and one user's manual for your convenience.

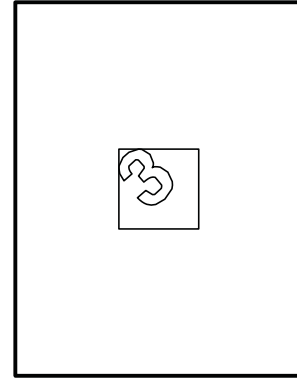
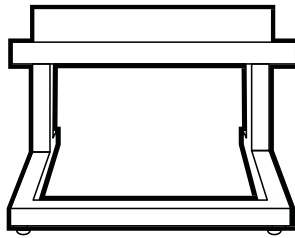
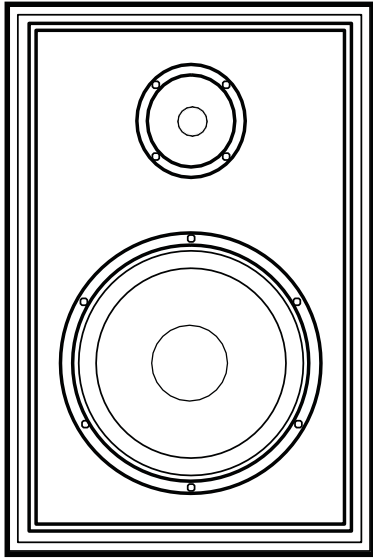

SUSTAINABLE MATERIALS

The Model Three does not utilize much plastic material in its construction or packaging. Where possible, KLH has elected to use more responsible materials, resulting in a product more in line with modern environmental sensitivities.



UNPACKING THE MODEL THREE

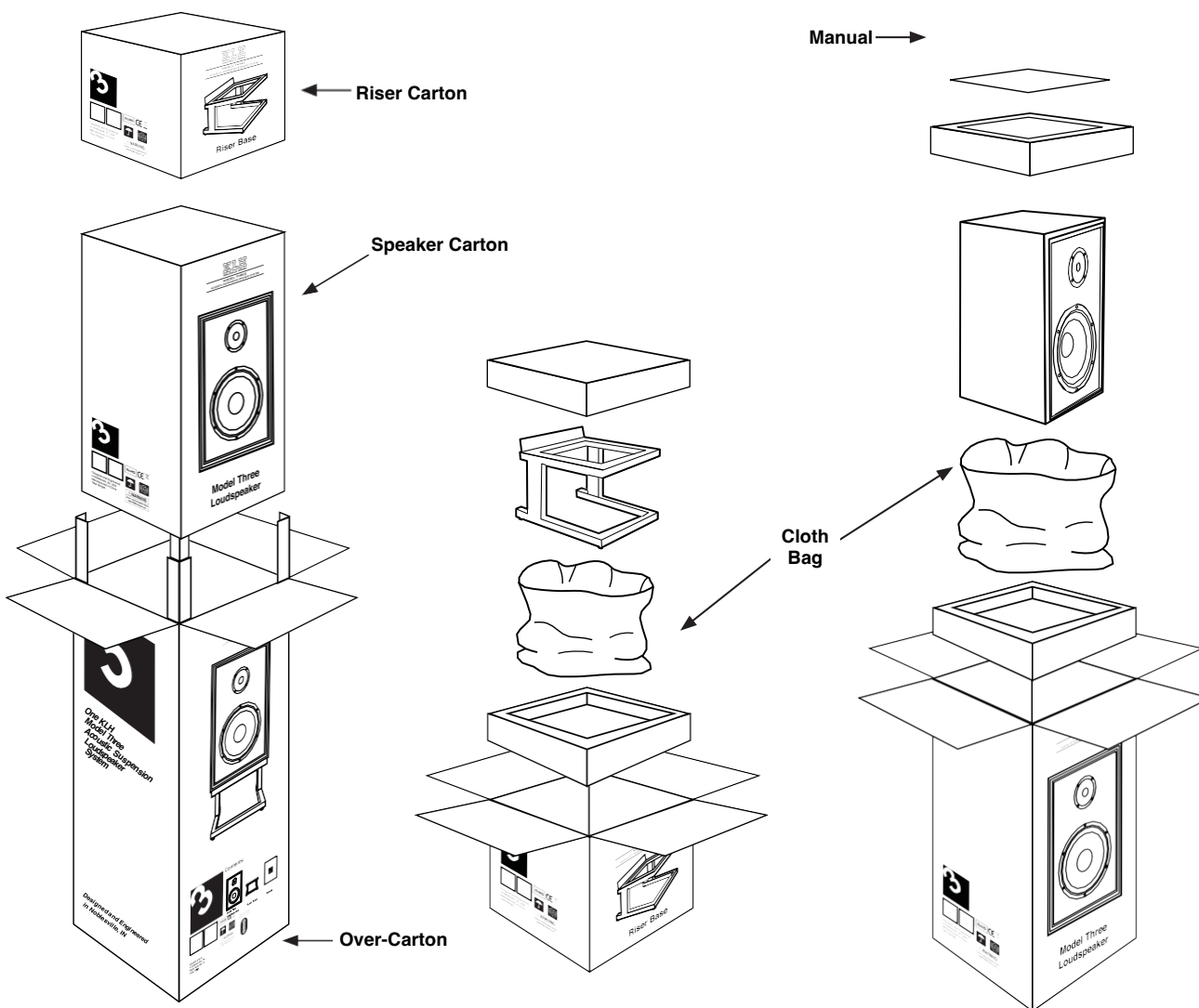

All components of the Model Three system are packaged carefully for maximum protection against damage. As with any high-quality audio product, it is advisable to keep the original packing materials. These materials will be beneficial to you if you ever need to transport the speakers.

The Model Three loudspeaker and the riser base are individually boxed, then packed together in an over-carton. The first step is to remove the two inner boxes from the carton. Next, remove the loudspeaker and its base from their separate packaging. Because of the bulk and weight of the loudspeaker, it is best if two people unpack the contents.

PLACING THE MODEL THREE ON SLANT RISER

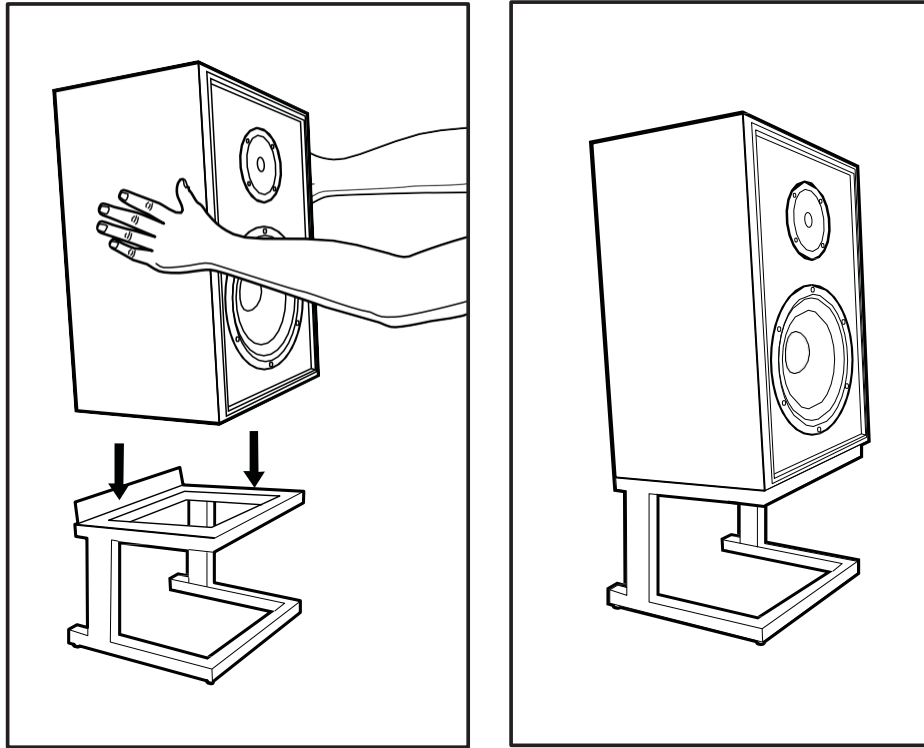

SPEAKER CONNECTION

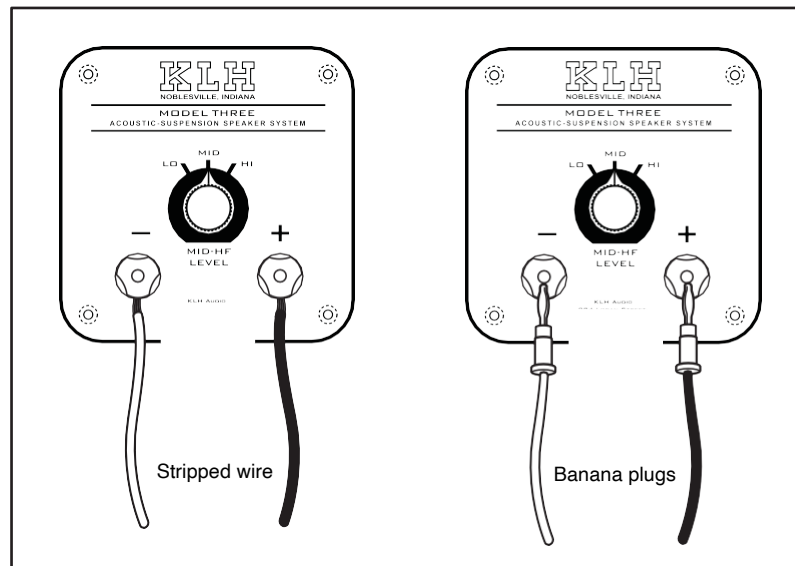

IMPORTANT! Turn your amplifier or receiver OFF before connecting your speakers. This action will avoid damage that could result from accidental shorting of the speaker cables.

You can use bare wire or banana, pin, or spade connectors with your loudspeaker binding posts. Tighten the posts firmly by hand but do not over tighten!

Correct polarity (or phase) is critical for proper imaging and bass performance. Connect one speaker at a time to ensure proper connection. The red (+) amplifier terminal connects to the red (+) speaker terminal. The same applies to the black (-) terminals. Make sure all wires are firmly fastened. Repeat this connection procedure for each speaker. Once connected, it is a good idea to go back and double-check each connection for correct polarity.

BREAK-IN

Your KLH Model Three loudspeakers will sound great right out of the box. But since your new speakers include many moving parts, these parts need time to adjust to one another. Therefore, some amount of "break-in" is necessary for your speakers to sound their best. KLH recommends playing your speakers at a moderate volume for at least 8 hours before any critical listening.

MODEL THREE POSITIONING AND ROOM ACOUSTICS

Room acoustics play a huge role in the sound reproduction characteristics of your Model Three loudspeakers. Experimenting with loudspeaker placement is a necessary step for optimum acoustic performance. Fortunately, the Model Three is very placement-friendly, and there are only a couple of factors that you need to keep in mind:

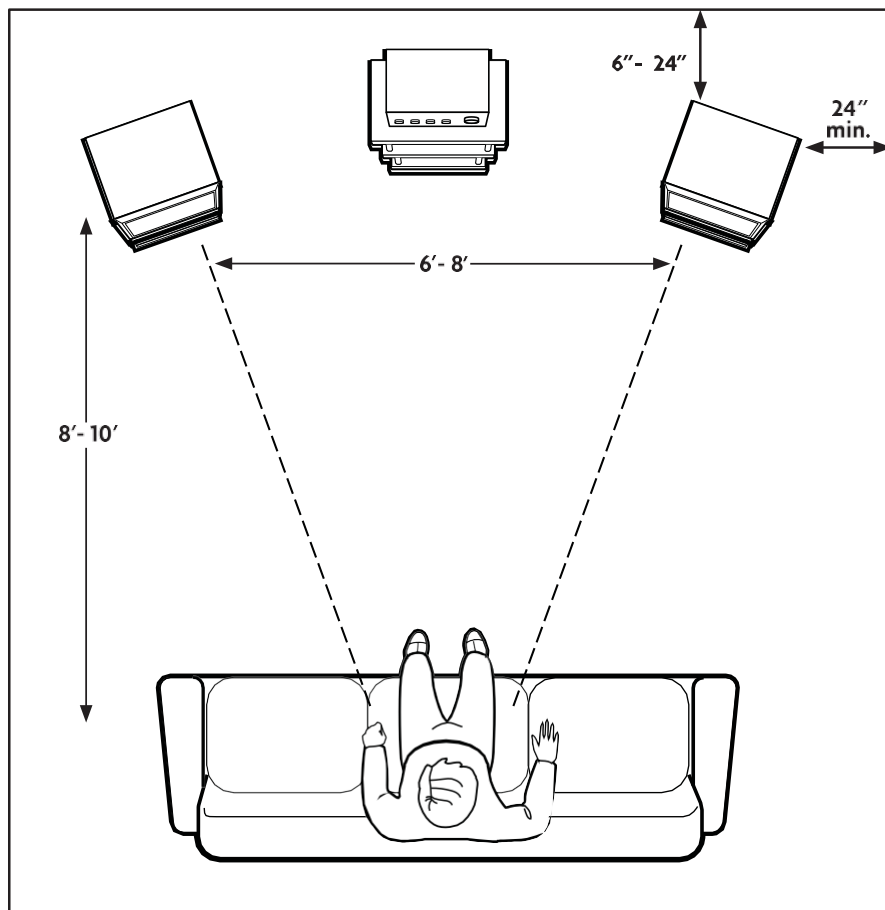

1. Low frequencies (below 400Hz) are heavily influenced by the loudspeaker's position relative to the boundaries of the listening room.

2. Mid & High frequencies (above 400Hz) are mostly influenced by the reflectivity ("live" or "dead" quality) of the listening room boundaries and the type of furnishings.

Hard surfaces, such as bare walls or wood floors, will reflect sound, whereas carpet and upholstered furniture absorb it. Too dead, and the listening space will sound dull and lifeless. But a highly reflective room will result in room reflections and echoes, which result in the room being too bright. Overly bright listening rooms are particularly problematic!

The primary goal is for the sound to predominate from the loudspeaker pair with a lesser amount of sound contributed by the room itself. An ideal listening space is neutral, meaning a room that contains characteristics of both a "live" and "dead" environment. One absorbent boundary (usually a carpeted floor) is enough to make the listening space not "too bright." Therefore, an example of

a good, basic listening room is a room characterized by walls, carpet (with pad), and plush furniture. If the room has wood or tile floors, it is recommended you utilize a large area rug.

Even rooms with a neutral acoustic behavior can still exhibit differences in the perceived acoustics simply due to the listening room dimensions and the precise location of the loudspeakers within the space. That is especially true concerning the boundary condition immediate to the loudspeaker's position. The less distance to a back wall or proximity to the corner of the listening room will enhance the low & middle bass characteristics. Keep that in mind during the listening evaluation and positioning of the loudspeaker. The KLH Model Three loudspeaker is tuned for 6 to 24 inches off the back wall and at least 24 inches from the corner of the listening room. For an otherwise neutral listening room, this is considered the best starting position when first setting up the Model Three's. (See illustration above.)

NOTE: KLH provides the user with the ability to control the loudspeaker's tonal balance to compliment the room acoustics for a listening space that may not be ideal.

CAUTION

- Do not place the speakers in direct sunlight or where they will be exposed to intense light.
- Avoid placing the speakers near power amplifiers, heat registers or other objects that generate large amounts of heat.
- Do not place speakers in humid or dusty spaces.

THREE-POSITION ACOUSTIC BALANCE SWITCH

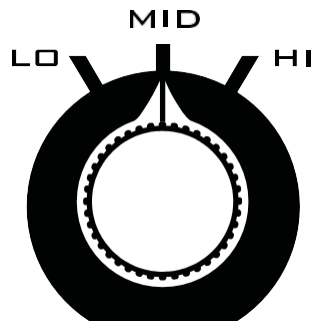

MID-HF
LEVEL

The selector switch located on the back of each loudspeaker allows users to tailor the output above 400Hz.

“HI” Position – This is the default position or 0dB. It is the preferred selection for neutral to dead listening spaces.

“MID” Position – This adjusts the loudspeaker -1.5dB above 400Hz. Use this setting for slightly live listening spaces.

“LO” Position – This adjusts the loudspeaker -3.0dB above 400Hz. Use this setting for very live listening spaces (for example, a room with a tile floor).

Of course, the selection is up to the user, and the user may want to experiment to determine the best selection for their listening taste. Please remember to set both speakers to the same setting; otherwise, a poor center image will result.

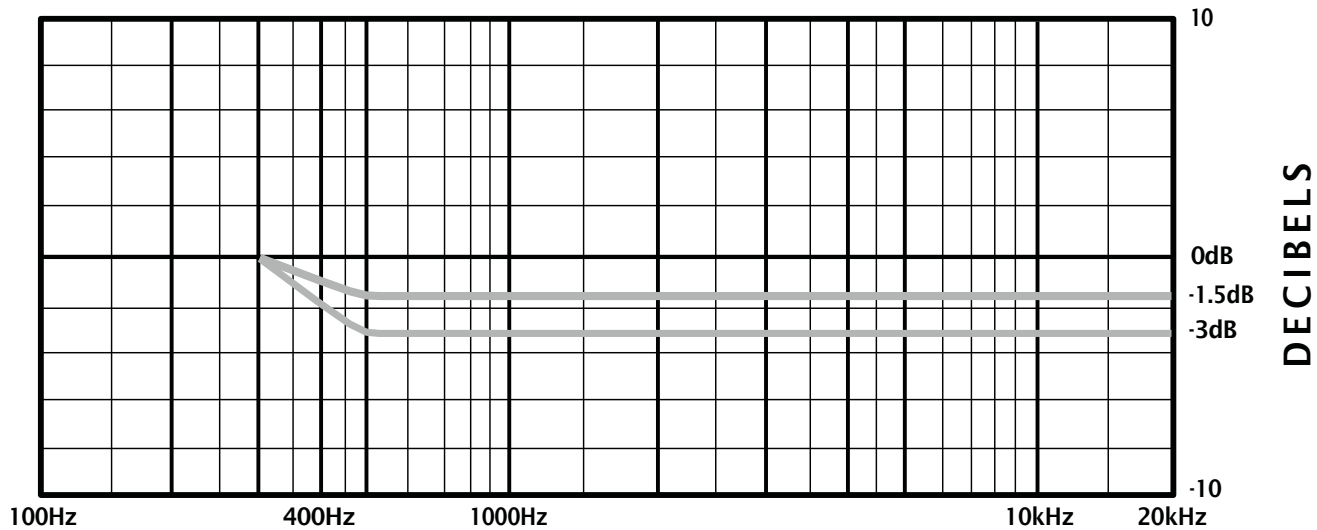

HOW TO EVALUATE STEREO LOUDSPEAKERS FOR SOUND AND ACCURACY

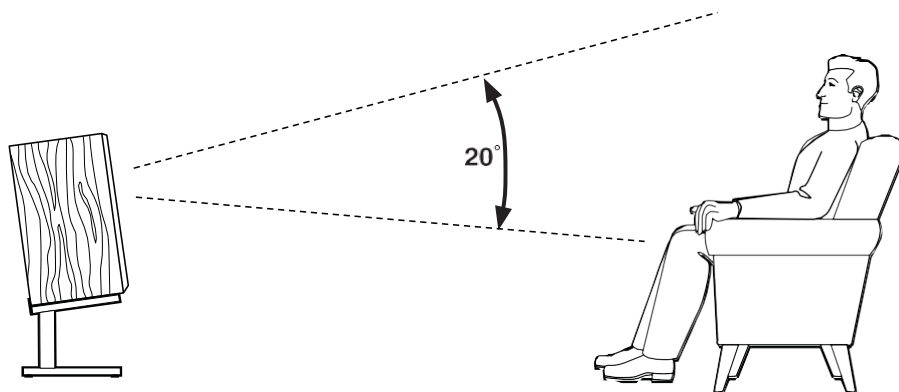

It is time to listen to the loudspeakers and evaluate their performance. Since the listening room contributes half of what you hear, proper evaluation and positioning adjustments are required to ensure the most rewarding listening experience. A little work here will go a long way. You want to start with a variety of music composed of tunes with which you are most familiar. Acoustic instruments and strong vocals are preferred since they are natural to the listener.

With the loudspeakers positioned and connected to a source, the first step is to confirm the loudspeakers are connected in phase. Pick a tune with a heavy vocal track. At a listening position centered between both speakers, listen specifically to the music vocals, and confirm they are centered directly between the two loudspeakers. The center image should be strong enough, and there should be no doubt about the location of the image. You should feel as if you can reach out and touch the vocalist. If the center image is vague or not there at all, recheck all connections. This step is easy, but you would be surprised how often it goes overlooked!

The next step is to evaluate the loudspeakers for musical accuracy, with particular attention given to low-frequency performance. This region (below 400Hz) is most influenced by the speaker's position in relation to the boundaries of the listening room. Slight changes can have a dramatic effect on the low-frequency output and overall balance of the system. You will want to experiment with moving the loudspeakers relative to the side and back walls of the listening room to achieve the best balance - keeping in mind that placing the loudspeaker closer to a wall or corner will enhance bass. You want to avoid speaker locations that result in weak or thin bass. Likewise, you want to avoid positions that make the loudspeakers sound boomy. Use several music tracks and try to find a happy medium. The KLH Model Three features a 3-position balance control that you will want to experiment with at this point. If you are experiencing particularly weak bass, switching this control to the -1.5dB or -3.0dB setting will make acoustic changes to the loudspeaker that will help you achieve the correct overall balance more quickly.

Once you are happy with the musical balance of the system, you will want to experiment with the toe-in to achieve the best imaging and soundstage. Accurate imaging and soundstage are the qualities that create the three-dimensional space around a pair of loudspeakers. When done correctly, this can enhance your musical enjoyment. More toe-in will increase image depth and localization; less toe-in will increase image width. You want the center image to be strong, but not at the expense of a wide soundstage. To do so, start with the loudspeakers pointed directly at the listener (strongest center-image). Then, slowly splay the speakers outward until you achieve the best combination of center image and soundstage. Again, you want to use a variety of music.

It is best to keep in mind that not all music will behave in the same manner. You will find some variation from artist to artist, but you should be able to find the best compromise for the types of music you enjoy.

That is it! Little preparation and time to experiment results in an enjoyable and rewarding listening experience!

NOTE: The Model Three loudspeaker exhibits a broad horizontal sound dispersion pattern. The sonic signature remains the same over a +/- 20° angle off the horizontal axis of the loudspeakers. As a result, the loudspeakers can be toed in-or-out about 20 degrees without any meaningful change in the direct sound from the loudspeaker arriving at the listening position. However, as the loudspeaker toe-in is adjusted, it does affect the sound energy reflected off the sidewall of the listening room, which directly affects the soundstage and ambiance.



CLEANING

Your Model Three speakers feature a genuine wood veneer. The finish is a low-gloss clear lacquer that only requires an occasional soft damp cloth. Be sure to clean with the grain, avoiding a circular or cross-grain motion. Do not use an abrasive cleaner. Avoid getting any part of the speaker components wet. Do not place wet objects (drinking glasses, potted plants, etc.) on top of your speakers—if allowed to soak in, even the smallest amount of water may permanently damage the loudspeaker finish.

WARRANTY

Our 10-year warranty begins from the purchase date of the item (Receipt Date). Original receipt of purchase must be retained for proof of purchase. For warranty or service issues, please contact your authorized KLH dealer. The warranty covers any production and/or material defects of the product. This warranty is non-transferable.

The following is NOT COVERED by the warranty:

1. Accidents, misuse, poor maintenance, electrical overloads such as lightning or voltage.
2. Incorrect use of the product.
3. Altered serial number.
4. Transportation costs for the service call.
5. Purchase of KLH products from an unauthorized reseller.

The replacement item cannot exceed the cost of the item under warranty. The supplier is responsible for only repair or replacement.

CUSTOMER SUPPORT

Scan below for customer support information or call 1-877-483-2497.



KLH and the KLH logo are registered trademarks of Innovative Technology Electronics, LLC.

DECLARATION OF CONFORMITY

You can download the complete EU conformity declaration from www.klhaudio.com/eudoc

This device complies with the essential requirements and other relevant provisions of ROHS directive: 2011/65/EU



The New Recast WEEE Directive (DIRECTIVE 2012/19/EU OF THE EUROPEAN PARLIAMENT AND OF THE COUNCIL of 4 July 2012 on waste electrical and electronic equipment (WEEE)).

1. All electrical and electronic products should be disposed of separately from the municipal waste stream via designated collection facilities appointed by the government or the local authorities.
2. The correct disposal of your old appliance will help prevent potential negative consequences for the environment and human health.
3. For more detailed information about disposal of your old appliance, please contact your city office, waste disposal service.

SPECIFICATIONS (all specifications for a single speaker)

Frequency Response:	46Hz – 20,000Hz +/- 3dB
Low Frequency Extension:	-10dB @ 35Hz
In-Room Sensitivity:	88dB @2.83V / 1M
Free-field Sensitivity:	85dB @ 2.83V / 1M
Power Handling:	150 Watts / 600 Watts Peak
Recommended Power Amplification:	30 Watts to 150 Watts Per Channel
In-Room Maximum SPL:	108dB
Impedance:	6 ohms (3.7 ohm minimum @320 Hz)
Horizontal Dispersion:	140° degrees
Features:	Three-Position Acoustic Balance Control
Crossover Frequency:	1,500Hz (2nd order electro-acoustic)
High Frequency Driver:	1" Aluminum Dome with soft rubber suspension
Low Frequency Driver:	8" Pulp-Paper Cone with reverse roll suspension
Enclosure Material:	Non-resonant die-cast aluminum frame Structurally Reinforced ¾" Medium Density Fiberboard
Inputs:	Five-Way Gold-Plated Binding Posts
Height:	28.25" (71.8cm) w/ included riser base 19.0" (48.2cm) w/o riser base
Width:	12.25" (31.1cm)
Depth:	11.5" (29.2cm) w/ included riser base 10.5" (26.7cm) w/o riser base
Weight:	29lbs. (13.2kg) w/o riser base 36lbs. (16.4kg) w/ included riser base
Included Accessories:	8° Slant Riser Base

Specifications subject to change without notice.



klhaudio.com

